

Submersible Pump in Discharge Tube

Amacan S

60 Hz

General Arrangement Drawings



Legal information/Copyright

General Arrangement Drawings Amacan S

KSB Aktiengesellschaft Halle

All rights reserved. Contents provided herein must neither be distributed, copied, reproduced, edited or processed for any other purpose, nor otherwise transmitted, published or made available to a third party without KSB's express written consent.

Subject to technical modification without prior notice.

© KSB Aktiengesellschaft Frankenthal 18.01.2012

Contents

Water Applications: Water Transport 4

 Submersible Pump in Discharge Tube 4

 Amacan S 4

 Designation 4

 Design and selection information 4

 Installation types 5

 General arrangement drawings [inch] 6

 Example of installation type BU (Amacan S 650 - 364 to 800 - 505) 6

 Example of installation type BU (Amacan S 800 - 535 to 1300 - 820) 9

 Example of installation type BG (Amacan S 650 - 364 to 800 - 505) 12

 Example of installation type BG (Amacan S 800 - 535 to 1300 - 820) 15

 Example of installation type CU (Amacan S 650 - 364 to 800 - 505) 18

 Example of installation type CU (Amacan S 800 - 535 to 1300 - 820) 21

 Example of installation type CG (Amacan S 650 - 364 to 800 - 505) 24

 Example of installation type CG (Amacan S 800 - 535 to 1300 - 820) 27

 Example of installation type DU (Amacan S 650 - 364 to 800 - 505) 30

 Example of installation type DU (Amacan S 800 - 535 to 1300 - 820) 33

 Example of installation type DG (Amacan S 650 - 364 to 800 - 505) 36

 Example of installation type DG (Amacan S 800 - 535 to 1300 - 820) 39

 Dimensions of the flow-straightening vane 42

 General arrangement drawings [mm] 44

 Example of installation type BU (Amacan S 650 - 364 to 800 - 505) 44

 Example of installation type BU (Amacan S 800 - 535 to 1300 - 820) 47

 Example of installation type BG (Amacan S 650 - 364 to 800 - 505) 50

 Example of installation type BG (Amacan S 800 - 535 to 1300 - 820) 53

 Example of installation type CU (Amacan S 650 - 364 to 800 - 505) 56

 Example of installation type CU (Amacan S 800 - 535 to 1300 - 820) 59

 Example of installation type CG (Amacan S 650 - 364 to 800 - 505) 62

 Example of installation type CG (Amacan S 800 - 535 to 1300 - 820) 65

 Example of installation type DU (Amacan S 650 - 364 to 800 - 505) 68

 Example of installation type DU (Amacan S 800 - 535 to 1300 - 820) 71

 Example of installation type DG (Amacan S 650 - 364 to 800 - 505) 74

 Example of installation type DG (Amacan S 800 - 535 to 1300 - 820) 77

 Dimensions of the flow-straightening vane 80

Water Applications: Water Transport

Submersible Pump in Discharge Tube

Amacan S



Designation

Example: Amacan S 1000-655 / 250 10 UT G2

Key to the designation

Code	Possible additions	Description
Amacan	–	Type series
S	–	Impeller type, e.g. S = mixed flow impeller
1000	–	Nominal diameter of the discharge tube [mm]
655	–	Nominal impeller diameter [mm]
250	–	Motor size
10	6 poles 8 poles 10 poles 12 poles	Number of motor poles
UT	UT UA	Motor version
G2	G2 G3	Material variant

Design and selection information

Information for pump selection

The guaranteed point of submersible pumps in discharge tubes is measured at a head 0.5 m above the motor (DIN 1184). The documented characteristic curves refer to this data. This must be taken into account when calculating system losses. The indicated heads and performance data apply to pumped fluids with a density $\rho=1 \text{ kg/dm}^3$ and a kinematic viscosity ν of up to $20 \text{ mm}^2/\text{s}$.

Intake chamber

Determine the min. water level $t_{1\text{min}}$ (see diagram in general arrangement drawing):

The min. water level $t_{1\text{min}}$ is the water level required in the pump's suction chamber to ensure:

- that there is a sufficient liquid cover above the hydraulic system (impeller) (shown in diagram depending on pump size)
- that the pump does not draw in air-entraining vortices (shown in diagram depending on flow rate)
- that there is no cavitation in the hydraulic system (check against the $\text{NPSH}_{\text{pump}}$ value indicated in the technical literature!). The following conditions must be met:
 - $\text{NPSH}_{\text{system}} > \text{NPSH}_{\text{pump}} + \text{safety allowance}$
 - $\text{NPSH}_{\text{system}} = 10.0 + (t_1 - t_3 - h_7/2)$
 - Safety allowance:
up to $Q_{\text{opt}} \Rightarrow 0.5 \text{ m}$
greater than $Q_{\text{opt}} \Rightarrow 1.0 \text{ m}$

Head (H)

The total head of the pump is composed as follows:

$$H = H_{\text{static}} + \Delta H_v$$

H_{static} (static head)

- Without discharge elbow – difference between the suction-side water level and the overflow edge
- With discharge elbow – difference between the suction-side water level and the discharge-side water level

ΔH_v (losses in the system)

- Starting 0.5 m downstream of the pump: e.g. pipe friction, elbows, swing check valves, etc.

Losses by inlet, riser and elbow

Losses are caused by the inlet, riser and elbow (or free discharge).

- Losses in the riser are taken into account in the documented characteristic curves up to the indicated reference level (0.5 m above the motor).
- Inlet and elbow losses are system losses and must be taken into account for selection.
- For information on structural requirements, pump installation and pump sump design refer to the KSB know-how brochure "Planning information: Amacan submersible pumps in discharge tubes" (ref. No. 0118.55).

Installation types

Six design variants are available for different installation types:¹⁾

Installation types

<p align="center">BU discharge tube Above floor design for installation in open intake chamber</p>	<p align="center">BG discharge tube Overflow design for installation in covered intake chamber for low suction-side water levels</p>
<p align="center">CU discharge tube Design with underfloor discharge line for installation in open intake chamber</p>	<p align="center">CG discharge tube Design with underfloor discharge line for installation in covered intake chamber for low suction-side water levels</p>
<p align="center">DU discharge tube Design with above floor discharge nozzle for installation in open intake chamber</p>	<p align="center">DG discharge tube Design with above floor discharge nozzle for installation in covered intake chamber for low suction-side water levels</p>

¹⁾ Refer to the General Arrangement Drawings for information on the various types (foundation dimensions, intake chamber, etc).

General arrangement drawings [inch]

Example of installation type BU (Amacan S 650 - 364 to 800 - 505)

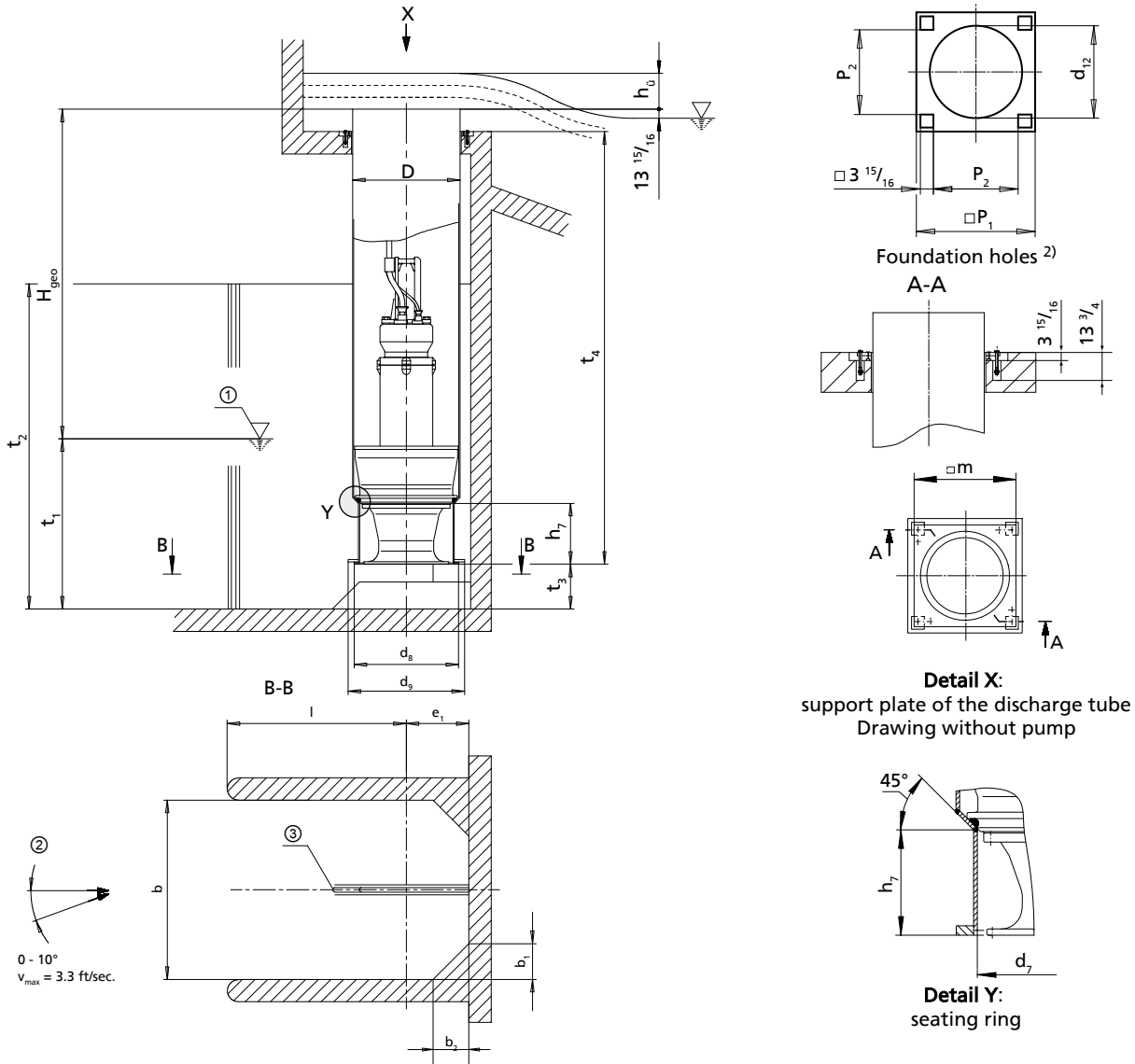

- ① Minimum water level (values see diagram on the next page)
- ② Approach flow
- ③ Flow-straightening vane (⇒ Page 42)

All dimensions in [inch]

Pump size	D	b	b ₁		b ₂		d ₇	d ₈	d ₉	d ₁₂
			without suction umbrella d ₈	with suction umbrella d ₉	without suction umbrella d ₈	with suction umbrella d ₉				
650-364	26	39 3/8	7 7/8	–	7 7/8	–	20 7/8	26	35 7/16	27 9/16
650-365	26	39 3/8	7 7/8	–	7 7/8	–	20 7/8	26	35 7/16	27 9/16
650-404	26	39 3/8	7 7/8	–	7 7/8	–	20 7/8	26	35 7/16	27 9/16
650-405	26	49 3/16	9 13/16	–	9 13/16	–	20 7/8	26	35 7/16	27 9/16
800-505	32	49 3/16	9 13/16	–	9 13/16	–	26 3/4	31 7/8	41 5/16	33 7/16

2) All dimensions for foundation holes apply to discharge tube design without intermediate flange.

All dimensions in [inch]

Pump size	e ₁ ³⁾		h ₇	l _{min.}	m	p ₁	p ₂	t ₃ ³⁾	t _{4 min.} ⁴⁾
	without suction umbrella d ₈	with suction umbrella d ₉							
650-364	16 ⁹ / ₁₆	21 ¹ / ₄	8 ⁷ / ₈	22 ¹³ / ₁₆	29 ¹ / ₂	33 ⁷ / ₁₆	23 ¹ / ₄	10 ¹ / ₄	92 ¹ / ₂
650-365	16 ⁹ / ₁₆	21 ¹ / ₄	8 ⁷ / ₈	22 ¹³ / ₁₆	29 ¹ / ₂	33 ⁷ / ₁₆	23 ¹ / ₄	10 ¹ / ₄	92 ¹ / ₂
650-404	16 ⁹ / ₁₆	21 ¹ / ₄	10 ⁷ / ₁₆	22 ¹³ / ₁₆	29 ¹ / ₂	33 ⁷ / ₁₆	23 ¹ / ₄	10 ¹ / ₄	100 ¹³ / ₁₆
650-405	16 ⁹ / ₁₆	21 ¹ / ₄	10 ⁷ / ₁₆	32 ¹¹ / ₁₆	29 ¹ / ₂	33 ⁷ / ₁₆	23 ¹ / ₄	12 ⁵ / ₈	107 ¹ / ₁₆
800-505	19 ¹¹ / ₁₆	24 ⁷ / ₁₆	13 ³ / ₁₆	29 ¹ / ₂	35 ¹³ / ₁₆	39 ³ / ₈	29 ¹ / ₈	12 ⁵ / ₈	104 ³ / ₄

t₂ = 1.1 x water level; max. 2 x t₁ (depending on head H and structure)

Height of corner lining (b₁ and b₂) like t₂

Permissible tolerances:

- Tolerances in building construction to DIN 18202, Part 4, Group B
- Welded constructions: B/F to DIN EN ISO 13920
- Tolerances for conical seat (detail Y): ISO 2768-mH

Loss diagram

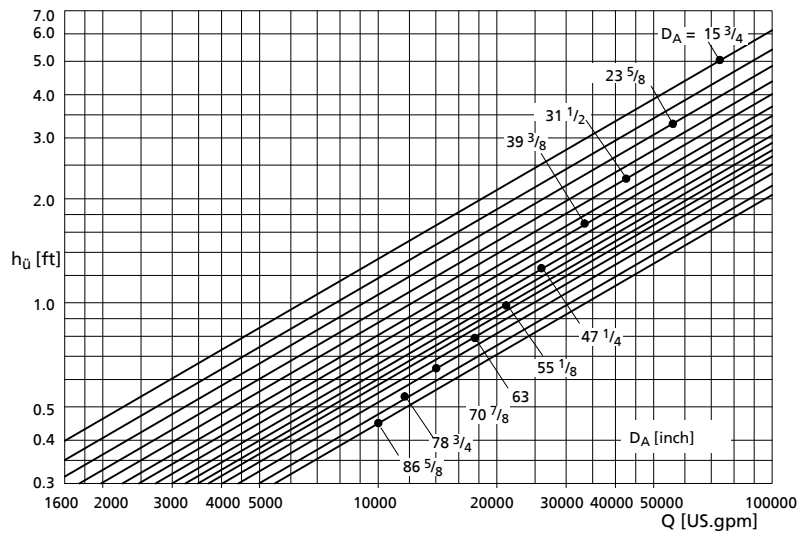
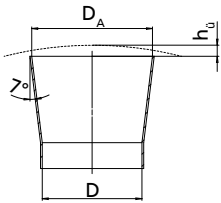

Overflow head h₀

Loss diagram

Calculation formulas:

$H = H_{geo} + \Delta H_v$

ΔH_v

- Overflow head h₀ (see diagram)
- Loss in the riser (pipe friction)
- Outlet loss $v^2/2g$ (v refers to D_a)

Overflow head h₀ depends on Q and the discharge diameter $\varnothing D_A$. The characteristic curve values only apply to unimpeded outlet in all directions; otherwise they are approximate values only.

3) Always observe this dimension.

4) Value for maximum motor length

Diagram for minimum water level t_1

Open chamber

t_1 [inch]

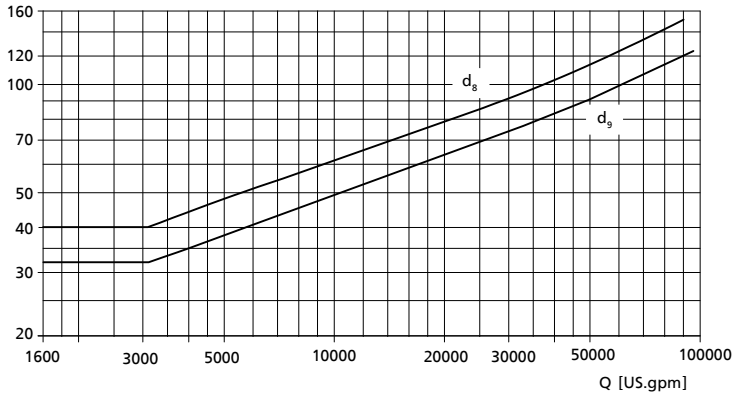

Minimum water level

d_8 = Design: **without** suction umbrella (standard)

d_9 = Design: **with** suction umbrella

Example of installation type BU (Amacan S 800 - 535 to 1300 - 820)

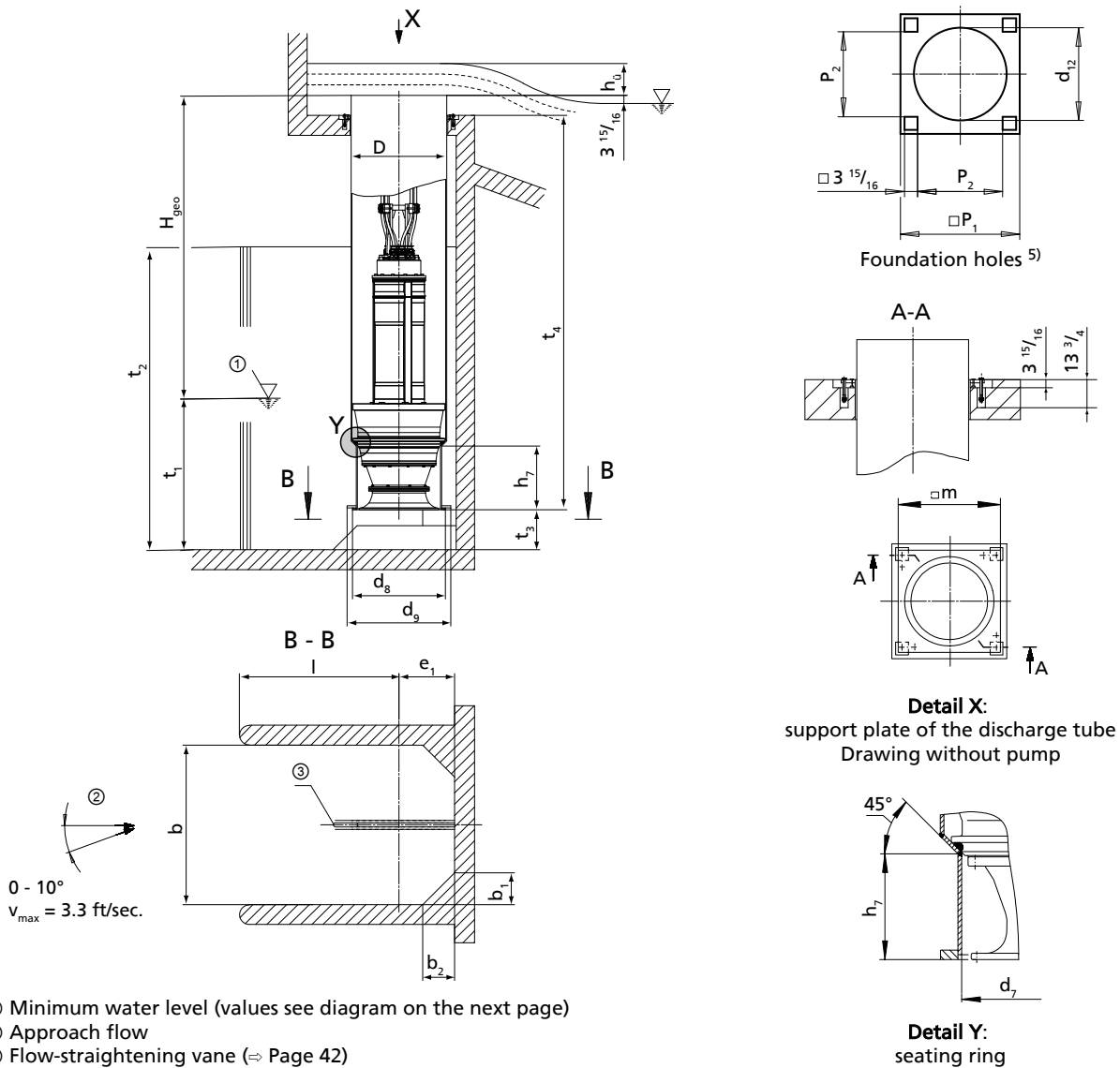

All dimensions in [inch]

Pump size	D	b	b ₁		b ₂		d ₇	d ₈	d ₉	d ₁₂
			without suction umbrella d ₈	with suction umbrella d ₉	without suction umbrella d ₈	with suction umbrella d ₉				
800 - 535	32	59 1/16	11 13/16	—	11 13/16	—	28 3/8	31 7/8	51 3/16	33 7/16
850 - 550	34 3/16	59 1/16	11 13/16	—	11 13/16	—	29 1/8	34 1/16	51 3/16	36 1/4
900 - 600	36	59 1/16	11 13/16	—	11 13/16	—	31 1/2	35 13/16	51 3/16	38 3/16
900 - 615	36	70 7/8	14 3/16	—	14 3/16	—	30 11/16	35 13/16	51 3/16	38 3/16
900 - 620	36	49 3/16	9 13/16	—	9 13/16	—	30 5/16	35 13/16	41 5/16	38 3/16
1000 - 655	40	70 7/8	14 3/16	—	14 3/16	—	36 1/4	39 15/16	59 1/16	42 1/8
1300 - 820	51 15/16	90 9/16	18 1/8	—	18 1/8	—	42 1/2	51 15/16	70 7/8	54 5/16

5) All dimensions for foundation holes apply to discharge tube design without intermediate flange.

All dimensions in [inch]

Pump size	e ₁ ⁶⁾		h ₇	l _{min.}	m	p ₁	p ₂	t ₃ ⁶⁾	t _{4 min.} ⁷⁾
	without suction umbrella d ₈	with suction umbrella d ₉							
800 - 535	19 11/16	29 1/2	12 13/16	39 3/8	35 13/16	39 3/8	29 1/8	14 15/16	110 1/4
850 - 550	20 11/16	29 1/2	14 3/4	38 3/8	38 9/16	41 5/16	31 1/8	14 15/16	127 15/16
900 - 600	21 5/8	29 1/2	16 5/16	37 3/8	41 5/16	44 1/8	33 7/8	14 15/16	126
900 - 615	21 5/8	29 1/2	16 9/16	49 3/16	41 5/16	44 1/8	33 7/8	17 5/16	126
900 - 620	21 5/8	24 7/16	14 3/8	27 9/16	41 5/16	44 1/8	33 7/8	12 5/8	126
1000 - 655	23 5/8	33 7/16	20 1/4	47 1/4	45 1/4	48 1/16	37 13/16	17 5/16	147 5/8
1300 - 820	29 1/2	39 3/8	21 7/16	61	57 1/2	59 13/16	49 5/8	22 1/16	153 9/16

t₂ = 1.1 x water level; max. 2 x t₁ (depending on head H and structure)

Height of corner lining (b₁ and b₂) like t₂

Permissible tolerances:

- Tolerances in building construction to DIN 18202, Part 4, Group B
- Welded constructions: B/F to DIN EN ISO 13920
- Tolerances for conical seat (detail Y): ISO 2768-mH

Loss diagram

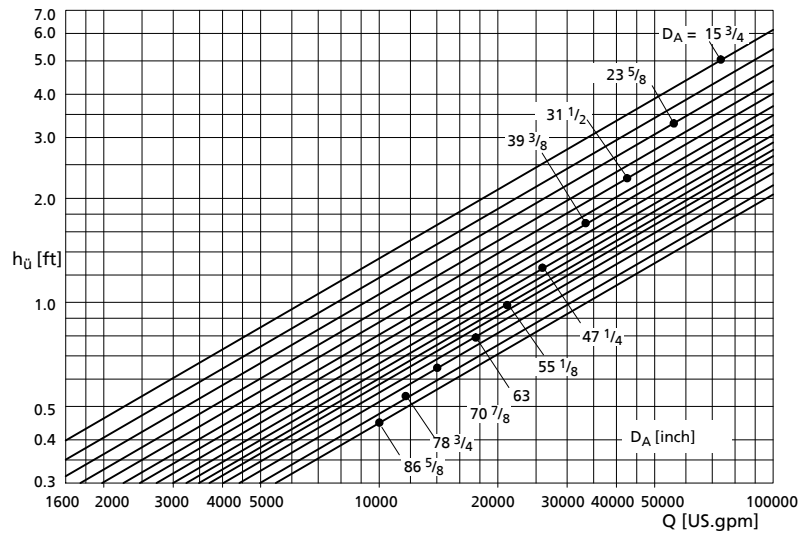
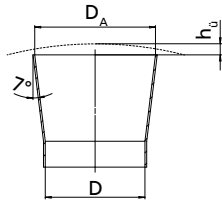

Overflow head h_u

Loss diagram

Calculation formulas:

$$H = H_{\text{geo}} + \Delta H_v$$

$$\Delta H_v$$

- Overflow head h_u (see diagram)
- Loss in the riser (pipe friction)
- Outlet loss v²/2g (v refers to D_A)

Overflow head h_u depends on Q and the discharge diameter ∅ D_A. The characteristic curve values only apply to unimpeded outlet in all directions; otherwise they are approximate values only.

⁶⁾ Always observe this dimension.

⁷⁾ Value for maximum motor length

Diagram for minimum water level t_1

Open chamber

t_1 [inch]

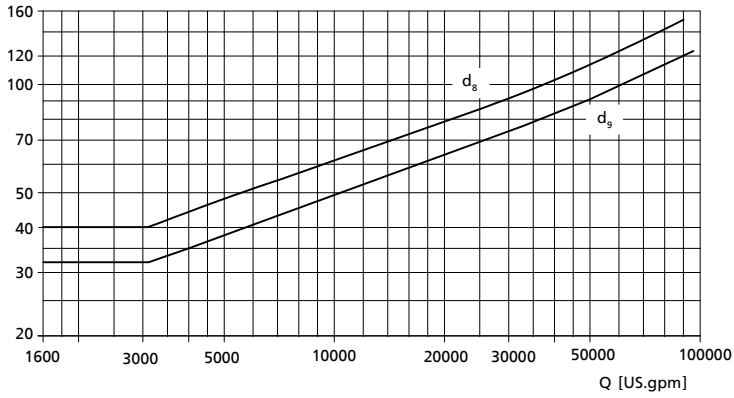

Minimum water level

d_8 = Design: **without** suction umbrella (standard)

d_9 = Design: **with** suction umbrella

Example of installation type BG (Amacan S 650 - 364 to 800 - 505)

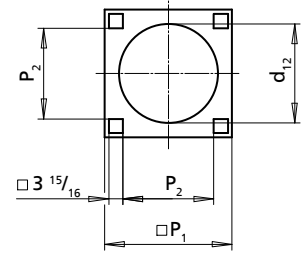
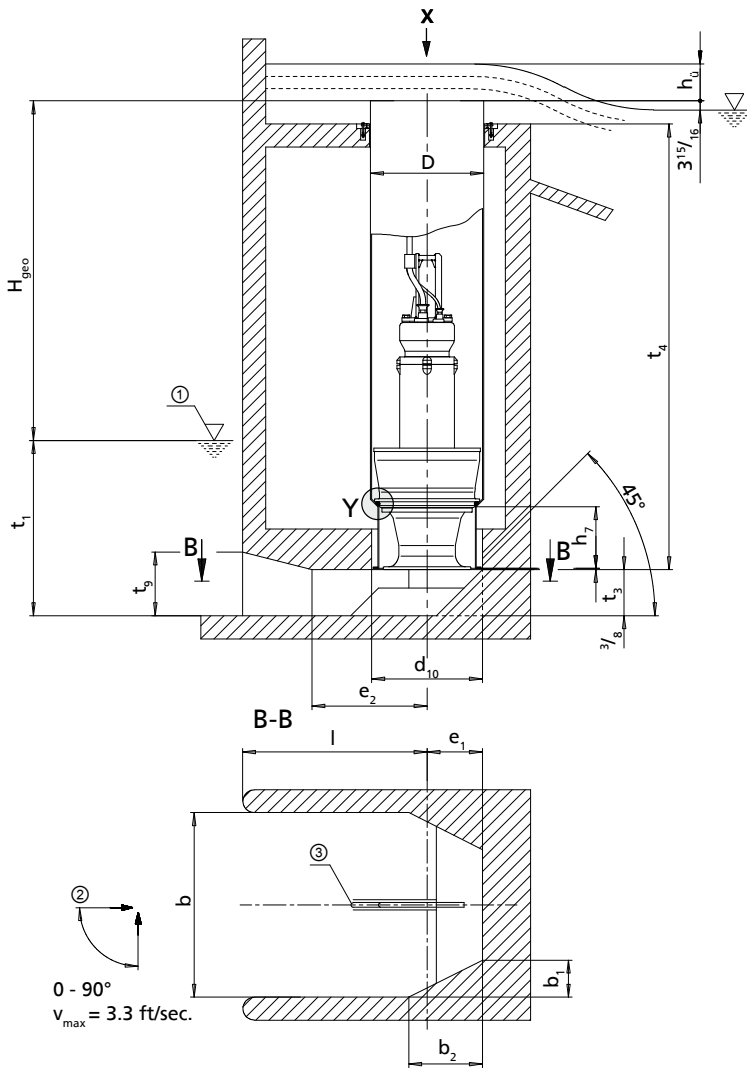

Foundation holes ⁸⁾

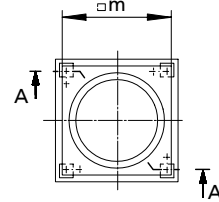
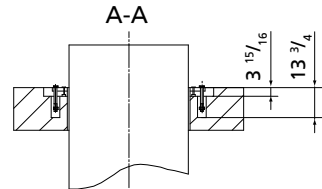

Detail X:
support plate of the discharge tube
Drawing without pump

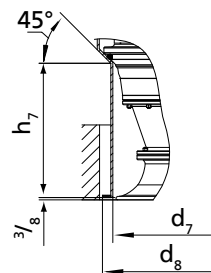

Detail Y:
seating ring

- ① Minimum water level (values see diagram on the next page)
- ② Approach flow
- ③ Flow-straightening vane (⇒ Page 42)

All dimensions in [inch]

Pump size	D	b	b ₁	b ₂	d ₇	d ₈	d ₁₀	d ₁₂	e ₁ ⁹⁾
650-364	26	39 3/8	7 7/8	15 3/4	20 7/8	21 5/8	23 5/8	27 9/16	11 13/16
650-365	26	39 3/8	7 7/8	15 3/4	20 7/8	21 5/8	23 5/8	27 9/16	11 13/16
650-404	26	39 3/8	7 7/8	15 3/4	20 7/8	21 5/8	23 5/8	27 9/16	11 13/16
650-405	26	49 3/16	9 13/16	19 11/16	20 7/8	26	27 3/16	27 9/16	14 3/4
800-505	32	49 3/16	9 13/16	19 11/16	26 3/4	27 9/16	28 15/16	33 7/16	14 3/4

⁸⁾ All dimensions for foundation holes apply to discharge tube design without intermediate flange.
⁹⁾ Always observe this dimension.

All dimensions in [inch]

Pump size	e ₂	h ₇	l _{min}	m	p ₁	p ₂	t ₃ ⁹⁾	t _{4 min} ¹⁰⁾	t ₉
650-364	19 11/16	8 7/8	39 3/8	29 1/2	33 7/16	23 1/4	10 1/4	92 1/2	14 3/4
650-365	19 11/16	8 7/8	39 3/8	29 1/2	33 7/16	23 1/4	10 1/4	92 1/2	14 3/4
650-404	19 11/16	10 7/16	39 3/8	29 1/2	33 7/16	23 1/4	10 1/4	100 13/16	14 3/4
650-405	24 5/8	10 7/16	49 3/16	29 1/2	33 7/16	23 1/4	12 5/8	107 1/16	18 1/2
800-505	24 5/8	13 3/16	49 3/16	35 13/16	39 3/8	29 1/8	12 5/8	104 3/4	18 1/2

t₂ = 1.1 x water level; max. 2 x t₁ (depending on head H and structure)
 Height of corner lining (b₁ and b₂) like t₂

Permissible tolerances:

- Tolerances in building construction to DIN 18202, Part 4, Group B
- Welded constructions: B/F to DIN EN ISO 13920
- Tolerances for conical seat (detail Y): ISO 2768-mH

Loss diagram

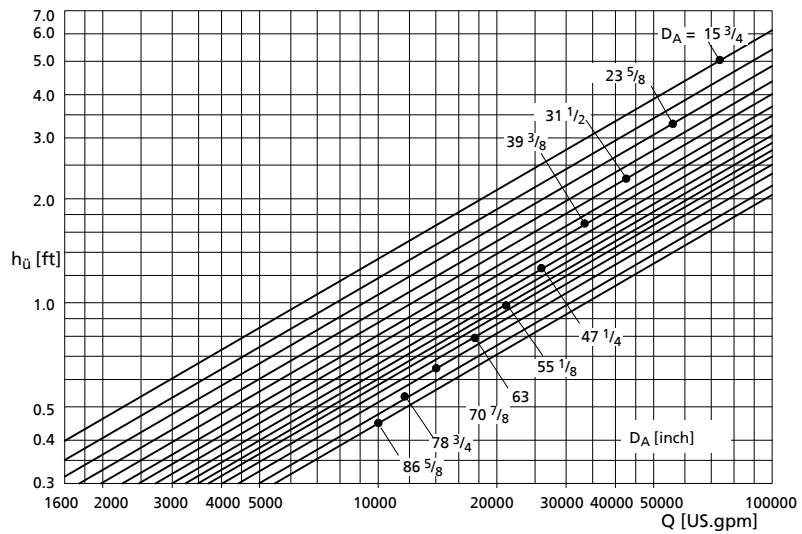
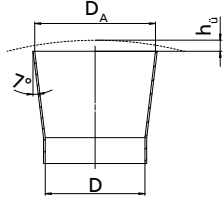

Overflow head h₀

Loss diagram

Calculation formulas:

$$H = H_{geo} + \Delta H_v$$

ΔH_v

- Overflow head h₀ (see diagram)
- Loss in the riser (pipe friction)
- Outlet loss $v^2/2g$ (v refers to D_A)

Overflow head h₀ depends on Q and the discharge diameter $\varnothing D_A$. The characteristic curve values only apply to unimpeded outlet in all directions; otherwise they are approximate values only.

¹⁰⁾ Value for maximum motor length

Diagram for minimum water level t_1

Covered chamber

t_1 [inch]

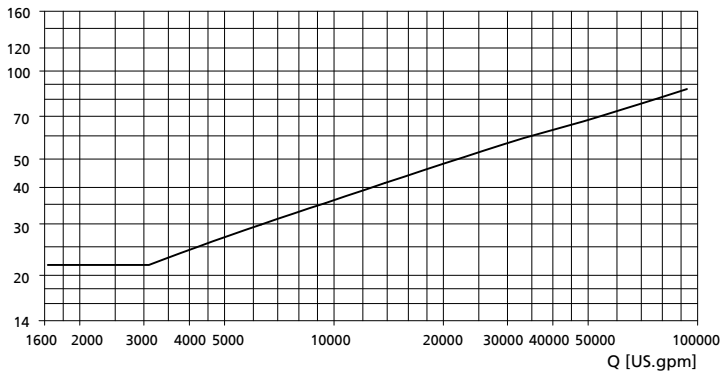

Minimum water level

Example of installation type BG (Amacan S 800 - 535 to 1300 - 820)

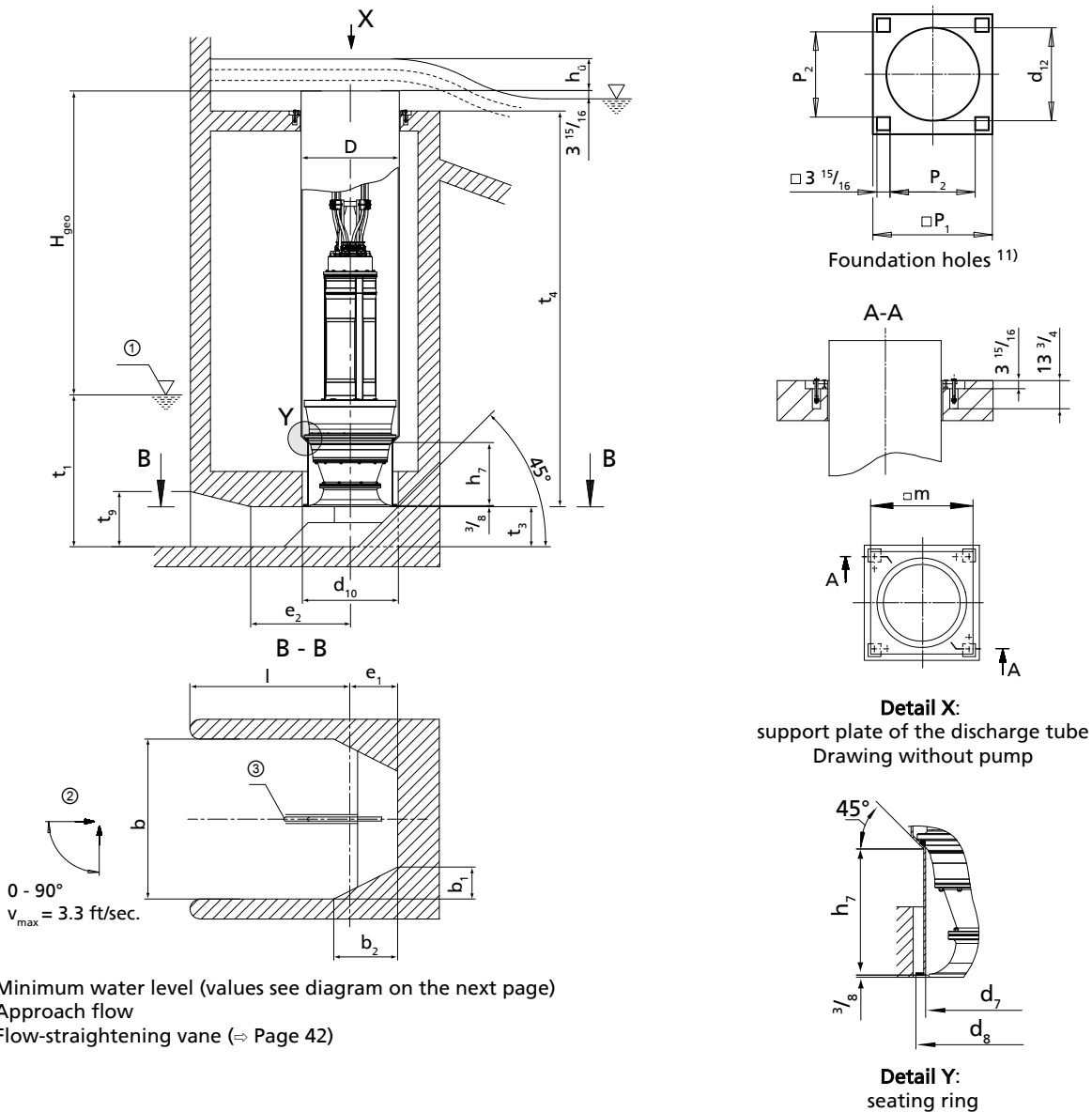

All dimensions in [inch]

Pump size	D	b	b ₁	b ₂	d ₇	d ₈	d ₁₀	d ₁₂	e ₁ ¹²⁾
800 - 535	32	59 1/16	11 13/16	23 5/8	28 3/8	33 1/16	34 13/16	33 7/16	17 11/16
850 - 550	34 3/16	59 1/16	11 13/16	23 5/8	29 1/8	33 1/16	34 13/16	36 1/4	17 11/16
900 - 600	36	59 1/16	11 13/16	23 5/8	31 1/2	32 5/16	33 7/8	38 3/16	17 11/16
900 - 615	36	70 7/8	14 3/16	28 3/8	30 11/16	35 13/16	37 5/8	38 3/16	20 1/2
900 - 620	36	49 3/16	9 13/16	19 11/16	30 5/16	31 1/8	32 11/16	38 3/16	16 5/16
1000 - 655	40	70 7/8	14 3/16	28 3/8	36 1/4	39 3/8	40 15/16	42 1/8	20 1/2
1300 - 820	51 15/16	90 9/16	18 1/8	36 1/4	42 1/2	51 3/16	53 9/16	54 5/16	26 3/4

11) All dimensions for foundation holes apply to discharge tube design without intermediate flange.
12) Always observe this dimension.

All dimensions in [inch]

Pump size	e ₂	h ₇	l _{min}	m	p ₁	p ₂	t ₃ ¹³⁾	t _{4 min} ¹⁴⁾	t ₉
800 - 535	29 1/2	12 13/16	59 1/16	35 3/16	39 3/8	29 1/8	14 15/16	110 1/4	22 7/16
850 - 550	29 1/2	14 3/4	59 1/16	38 9/16	41 5/16	31 1/8	14 15/16	127 15/16	22 7/16
900 - 600	29 1/2	16 5/16	59 1/16	41 5/16	44 1/8	33 7/8	14 15/16	126	22 7/16
900 - 615	35 7/16	16 9/16	70 7/8	41 5/16	44 1/8	33 7/8	17 5/16	126	26
900 - 620	24 5/8	14 3/8	49 3/16	41 5/16	44 1/8	33 7/8	12 5/8	126	18 1/2
1000 - 655	35 7/16	20 1/4	70 7/8	45 1/4	48 1/16	37 13/16	17 5/16	147 5/8	26
1300 - 820	45 1/4	21 7/16	90 9/16	57 1/2	59 13/16	49 5/8	22 1/16	153 9/16	33 7/16

t₂ = 1.1 x water level; max. 2 x t₁ (depending on head H and structure)

Height of corner lining (b₁ and b₂) like t₂

Permissible tolerances:

- Tolerances in building construction to DIN 18202, Part 4, Group B
- Welded constructions: B/F to DIN EN ISO 13920
- Tolerances for conical seat (detail Y): ISO 2768-mH

Loss diagram

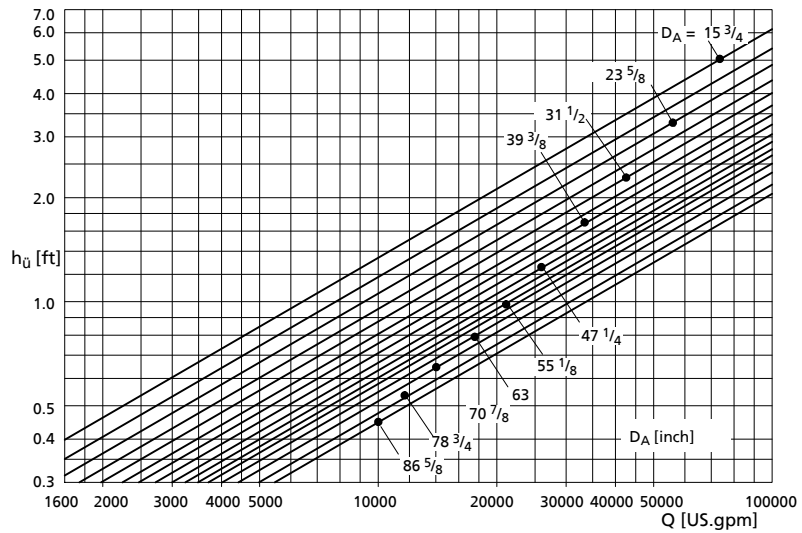
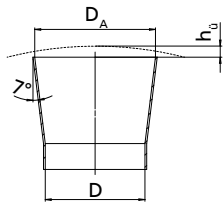

Overflow head h_u

Loss diagram

Calculation formulas:

$$H = H_{\text{geo}} + \Delta H_v$$

ΔH_v

- Overflow head h_u (see diagram)
- Loss in the riser (pipe friction)
- Outlet loss $v^2/2g$ (v refers to D_A)

Overflow head h_u depends on Q and the discharge diameter \varnothing D_A. The characteristic curve values only apply to unimpeded outlet in all directions; otherwise they are approximate values only.

¹³⁾ Always observe this dimension.

¹⁴⁾ Value for maximum motor length

Diagram for minimum water level t_1

Covered chamber

t_1 [inch]

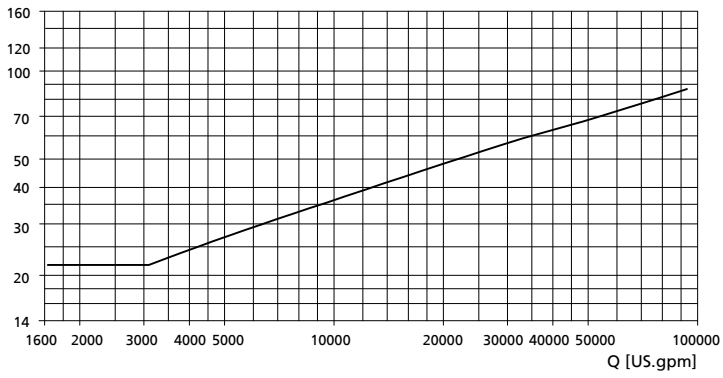

Minimum water level

Example of installation type CU (Amacan S 650 - 364 to 800 - 505)

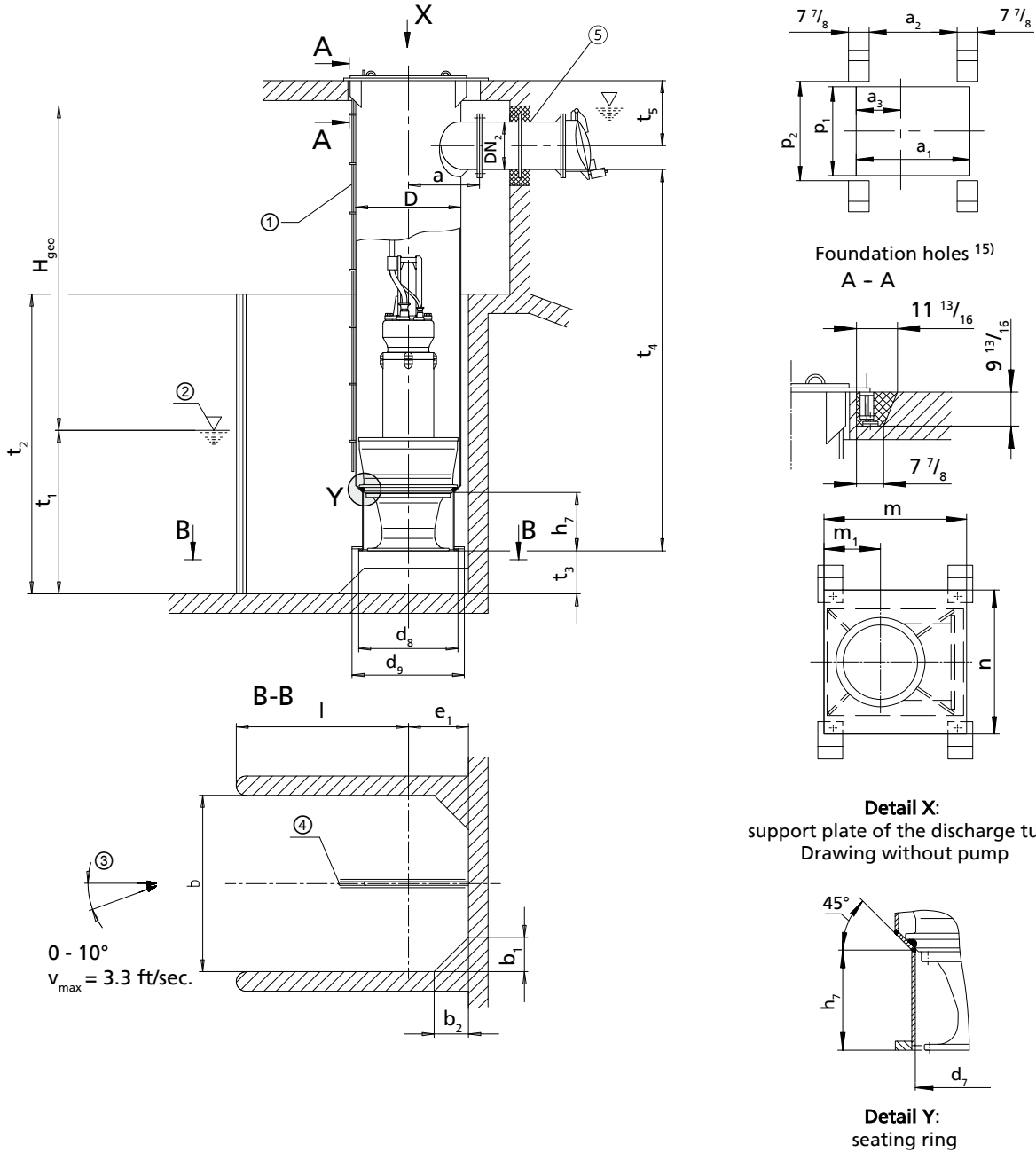

- ① Vent line
- ② Minimum water level (values see diagram on the next page)
- ③ Approach flow
- ④ Flow-straightening vane (⇒ Page 42)
- ⑤ Connect the discharge pipe to the discharge tube without transmitting any stresses and strains.

¹⁵⁾ All dimensions for foundation holes apply to discharge tube design without intermediate flange.

All dimensions in [inch]

Pump size	D	DN ₂ min	DN ₂ max	a	a ₁ ¹⁶⁾	a ₂ ¹⁶⁾	a ₃ ¹⁶⁾	b	b ₁		b ₂		d ₇
									without suction umbrella d ₈	with suction umbrella d ₉	without suction umbrella d ₈	with suction umbrella d ₉	
650-364	26	15 3/4	23 5/8	24	41 5/16	31 1/2	15 15/16	39 3/8	7 7/8	–	7 7/8	–	20 7/8
650-365	26	15 3/4	23 5/8	24	41 5/16	31 1/2	15 15/16	39 3/8	7 7/8	–	7 7/8	–	20 7/8
650-404	26	15 3/4	23 5/8	24	41 5/16	31 1/2	15 15/16	39 3/8	7 7/8	–	7 7/8	–	20 7/8
650-405	26	15 3/4	23 5/8	24	41 5/16	31 1/2	15 15/16	49 3/16	9 13/16	–	9 13/16	–	20 7/8
800-505	32	19 11/16	31 1/2	27 9/16	48 1/16	38 3/16	18 7/8	49 3/16	9 13/16	–	9 13/16	–	26 3/4

All dimensions in [inch]

Pump size	d ₈	d ₉	e ₁ ¹⁷⁾		h ₇	l _{min}	m ¹⁶⁾	m ₁ ¹⁶⁾	n ¹⁶⁾	p ₁ ¹⁶⁾	p ₂ ¹⁶⁾	t ₃ ¹⁷⁾	t _{4 min} ¹⁸⁾	t _{5 min} ¹⁶⁾
			without suction umbrella d ₈	with suction umbrella d ₉										
650-364	26	35 7/16	16 9/16	21 1/4	8 7/8	22 13/16	43 5/16	16 15/16	45 11/16	33 7/8	37 13/16	10 1/4	92 1/2	28 3/8
650-365	26	35 7/16	16 9/16	21 1/4	8 7/8	22 13/16	43 5/16	16 15/16	45 11/16	33 7/8	37 13/16	10 1/4	92 1/2	28 3/8
650-404	26	35 7/16	16 9/16	21 1/4	10 7/16	22 13/16	43 5/16	16 15/16	45 11/16	33 7/8	37 13/16	10 1/4	102 3/8	28 3/8
650-405	26	35 7/16	16 9/16	21 1/4	10 7/16	32 11/16	43 5/16	16 15/16	45 11/16	33 7/8	37 13/16	12 5/8	108 1/4	28 3/8
800-505	31 7/8	41 5/16	16 11/16	24 7/16	13 3/16	29 1/2	50	19 7/8	54 1/8	42 5/16	46 1/4	12 5/8	106 5/16	32 7/8

 $t_2 = 1.1 \times \text{water level}$; max. $2 \times t_1$ (depending on head H and structure)

 Height of corner lining (b₁ and b₂) like t₂

Permissible tolerances:

- Tolerances in building construction to DIN 18202, Part 4, Group B
- Welded constructions: B/F to DIN EN ISO 13920
- Tolerances for conical seat (detail Y): ISO 2768-mH
- Discharge flanges to DIN EN 1092-1 PN6, DIN EN 1092-2 PN6

 16) Selected for DN₂ max.

17) Always observe this dimension.

18) Value for maximum motor length

Loss diagram

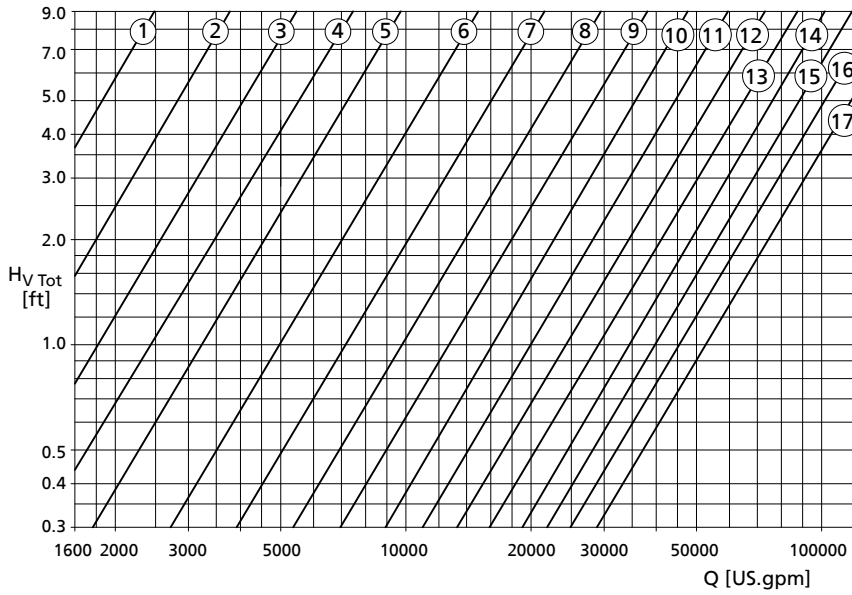

- ① - DN₂ = 7 7/8 inch
- ② - DN₂ = 9 13/16 inch
- ③ - DN₂ = 11 13/16 inch
- ④ - DN₂ = 13 3/4 inch
- ⑤ - DN₂ = 15 3/4 inch
- ⑥ - DN₂ = 19 11/16 inch

- ⑦ - DN₂ = 23 5/8 inch
- ⑧ - DN₂ = 27 9/16 inch
- ⑨ - DN₂ = 31 1/2 inch
- ⑩ - DN₂ = 35 7/16 inch
- ⑪ - DN₂ = 39 3/8 inch
- ⑫ - DN₂ = 43 5/16 inch

- ⑬ - DN₂ = 47 1/4 inch
- ⑭ - DN₂ = 51 3/16 inch
- ⑮ - DN₂ = 55 1/8 inch
- ⑯ - DN₂ = 59 1/16 inch
- ⑰ - DN₂ = 63 inch

Calculation formulas:

$$H = H_{geo} + \Delta H_v$$

ΔH_v

- Loss in the riser (pipe friction)
- $H_{v,ges.}$ (see diagram)

$H_{v,ges.}$ comprises:

- Elbow
- Discharge pipe length = 5 x DN₂
- Swing check valve
- Outlet losses $v^2/2g$

Diagram for minimum water level t₁

Open chamber

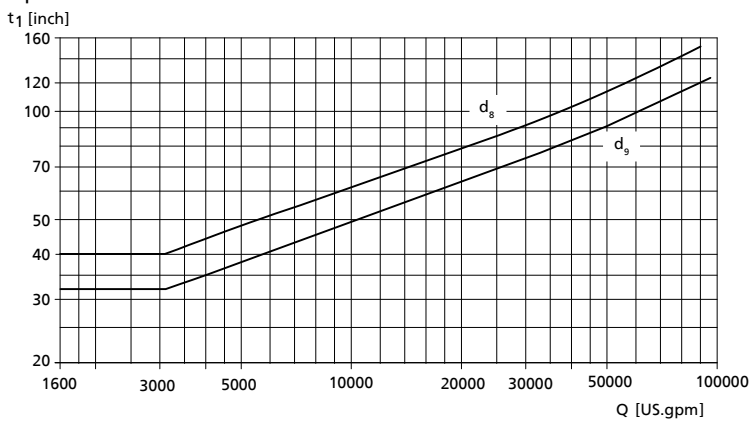

Minimum water level

d_8 = Design: **without** suction umbrella (standard)

d_9 = Design: **with** suction umbrella

Example of installation type CU (Amacan S 800 - 535 to 1300 - 820)

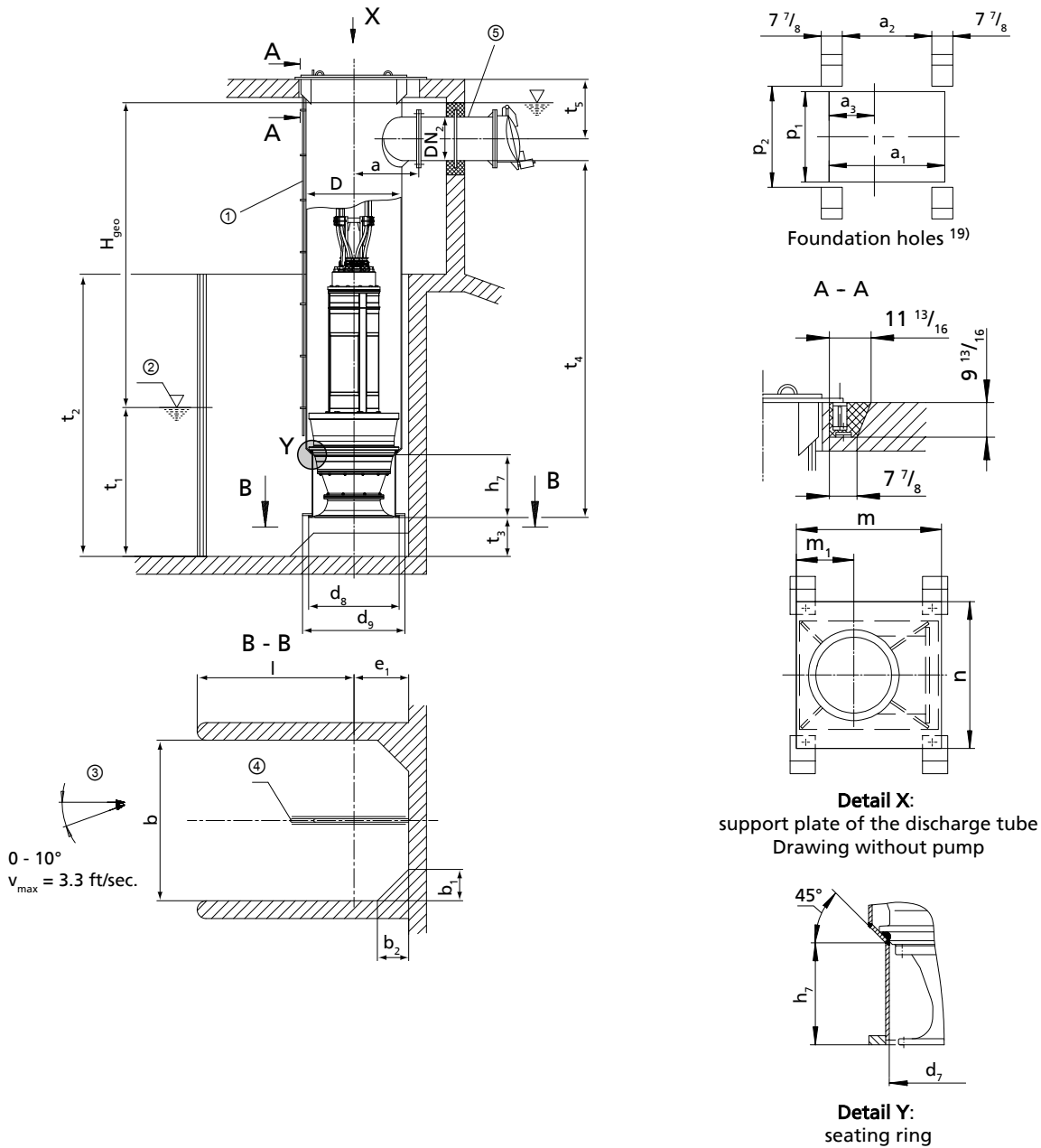

19) All dimensions for foundation holes apply to discharge tube design without intermediate flange.

All dimensions in [inch]

Pump size	D	DN ₂ min	DN ₂ max	a	a ₁ ²⁰⁾	a ₂ ²⁰⁾	a ₃ ²⁰⁾	b	b ₁		b ₂		d ₇
									without suction umbrella d ₈	with suction umbrella d ₉	without suction umbrella d ₈	with suction umbrella d ₉	
800 - 535	32	19 11/16	31 1/2	27 9/16	48 1/16	38 3/16	18 7/8	59 1/16	11 13/16	–	11 13/16	–	28 3/8
850 - 550	34 3/16	19 11/16	31 1/2	28 3/4	50 3/16	40 3/16	19 7/8	59 1/16	11 13/16	–	11 13/16	–	29 1/8
900 - 600	36	23 5/8	35 7/16	29 15/16	51 15/16	42 1/8	20 7/8	59 1/16	11 13/16	–	11 13/16	–	31 1/2
900 - 615	36	23 5/8	35 7/16	29 15/16	51 15/16	42 1/8	20 7/8	70 7/8	14 3/16	–	14 3/16	–	30 11/16
900 - 620	36	23 5/8	35 7/16	29 15/16	51 15/16	42 1/8	20 7/8	49 3/16	9 13/16	–	9 13/16	–	30 5/16
1000 - 655	40	27 9/16	39 3/8	31 7/8	56 5/16	45 11/16	22 13/16	70 7/8	14 3/16	–	14 3/16	–	36 1/4
1300 - 820	51 15/16	39 3/8	51 3/16	37 13/16	67 11/16	57 7/8	28 3/8	90 9/16	18 1/8	–	18 1/8	–	42 1/2

All dimensions in [inch]

Pump size	d ₈	d ₉	e ₁ ²¹⁾		h ₇	l _{min}	m ²²⁾	m ₁ ²²⁾	n ²²⁾	p ₁ ²²⁾	p ₂ ²²⁾	t ₃ ²¹⁾	t _{4 min} ²³⁾	t ₅ ²²⁾
			without suction umbrella d ₈	with suction umbrella d ₉										
800 - 535	31 7/8	51 3/16	19 11/16	29 1/2	12 13/16	39 3/8	50	19 7/8	54 1/8	42 5/16	46 1/4	14 15/16	110 1/4	32 7/8
850 - 550	34 1/16	51 3/16	20 11/16	29 1/2	14 3/4	38 3/8	52 3/16	20 7/8	54 1/8	42 5/16	46 1/4	14 15/16	127 15/16	32 7/8
900 - 600	35 13/16	51 3/16	21 5/8	29 1/2	16 5/16	37 3/8	54 5/16	22 1/16	58 1/4	46 7/16	50 3/8	14 15/16	126	36 7/16
900 - 615	35 13/16	51 3/16	21 5/8	29 1/2	16 9/16	49 3/16	54 5/16	22 1/16	58 1/4	46 7/16	50 3/8	17 5/16	126	36 7/16
900 - 620	35 13/16	41 5/16	21 5/8	24 7/16	14 3/8	27 9/16	54 5/16	22 1/16	58 1/4	46 7/16	50 3/8	12 5/8	126	36 7/16
1000 - 655	39 15/16	59 1/16	23 5/8	33 7/16	20 1/4	47 1/4	59 13/16	24 5/8	63 3/4	50 3/8	54 5/16	17 5/16	147 5/8	38 9/16
1300 - 820	51 15/16	70 7/8	29 1/2	39 3/8	21 7/16	61	71 1/4	30 1/8	77 3/16	63 3/4	67 11/16	22 1/16	153 9/16	46 7/16

 $t_2 = 1.1 \times \text{water level}$; max. $2 \times t_1$ (depending on head H and structure)

 Height of corner lining (b₁ and b₂) like t₂

Permissible tolerances:

- Tolerances in building construction to DIN 18202, Part 4, Group B
- Welded constructions: B/F to DIN EN ISO 13920
- Tolerances for conical seat (detail Y): ISO 2768-mH
- Discharge flanges to DIN EN 1092-1 PN6, DIN EN 1092-2 PN6

20) Selected for DN2 max.

21) Always observe this dimension.

22) Selected for DN2 max.

23) Value for maximum motor length

Loss diagram

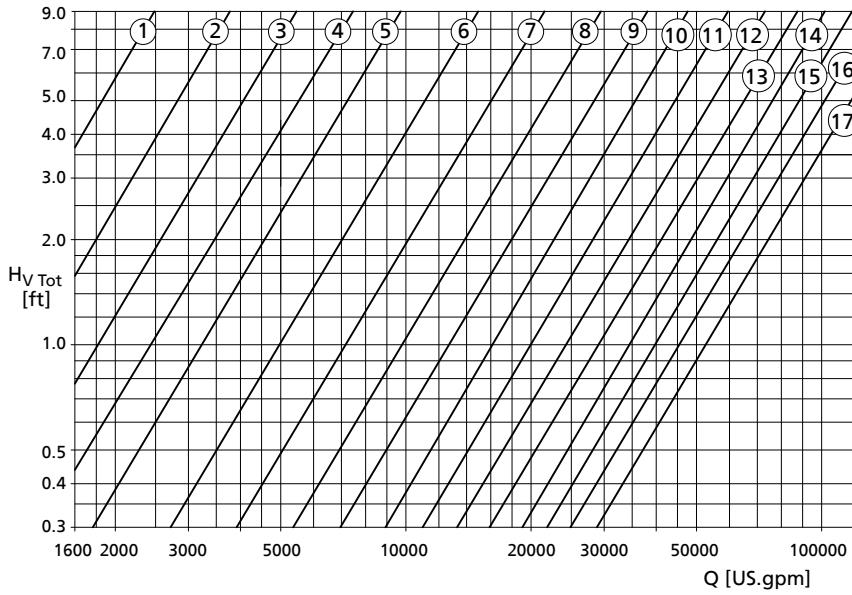

- ① - DN₂ = 7 7/8 inch
- ② - DN₂ = 9 13/16 inch
- ③ - DN₂ = 11 13/16 inch
- ④ - DN₂ = 13 3/4 inch
- ⑤ - DN₂ = 15 3/4 inch
- ⑥ - DN₂ = 19 11/16 inch

- ⑦ - DN₂ = 23 5/8 inch
- ⑧ - DN₂ = 27 9/16 inch
- ⑨ - DN₂ = 31 1/2 inch
- ⑩ - DN₂ = 35 7/16 inch
- ⑪ - DN₂ = 39 3/8 inch
- ⑫ - DN₂ = 43 5/16 inch

- ⑬ - DN₂ = 47 1/4 inch
- ⑭ - DN₂ = 51 3/16 inch
- ⑮ - DN₂ = 55 1/8 inch
- ⑯ - DN₂ = 59 1/16 inch
- ⑰ - DN₂ = 63 inch

Calculation formulas:

$$H = H_{geo} + \Delta H_v$$

ΔH_v

- Loss in the riser (pipe friction)
- $H_{v,ges.}$ (see diagram)

$H_{v,ges.}$ comprises:

- Elbow
- Discharge pipe length = 5 x DN₂
- Swing check valve
- Outlet losses $v^2/2g$

Diagram for minimum water level t:

Open chamber

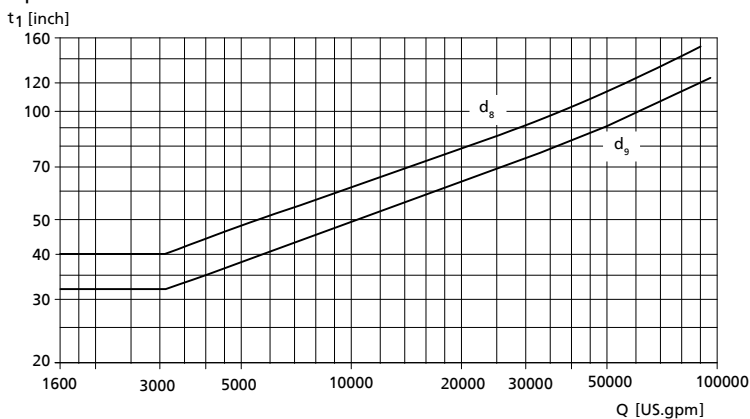

Minimum water level

d_8 = Design: **without** suction umbrella (standard)

d_9 = Design: **with** suction umbrella

Example of installation type CG (Amacan S 650 - 364 to 800 - 505)

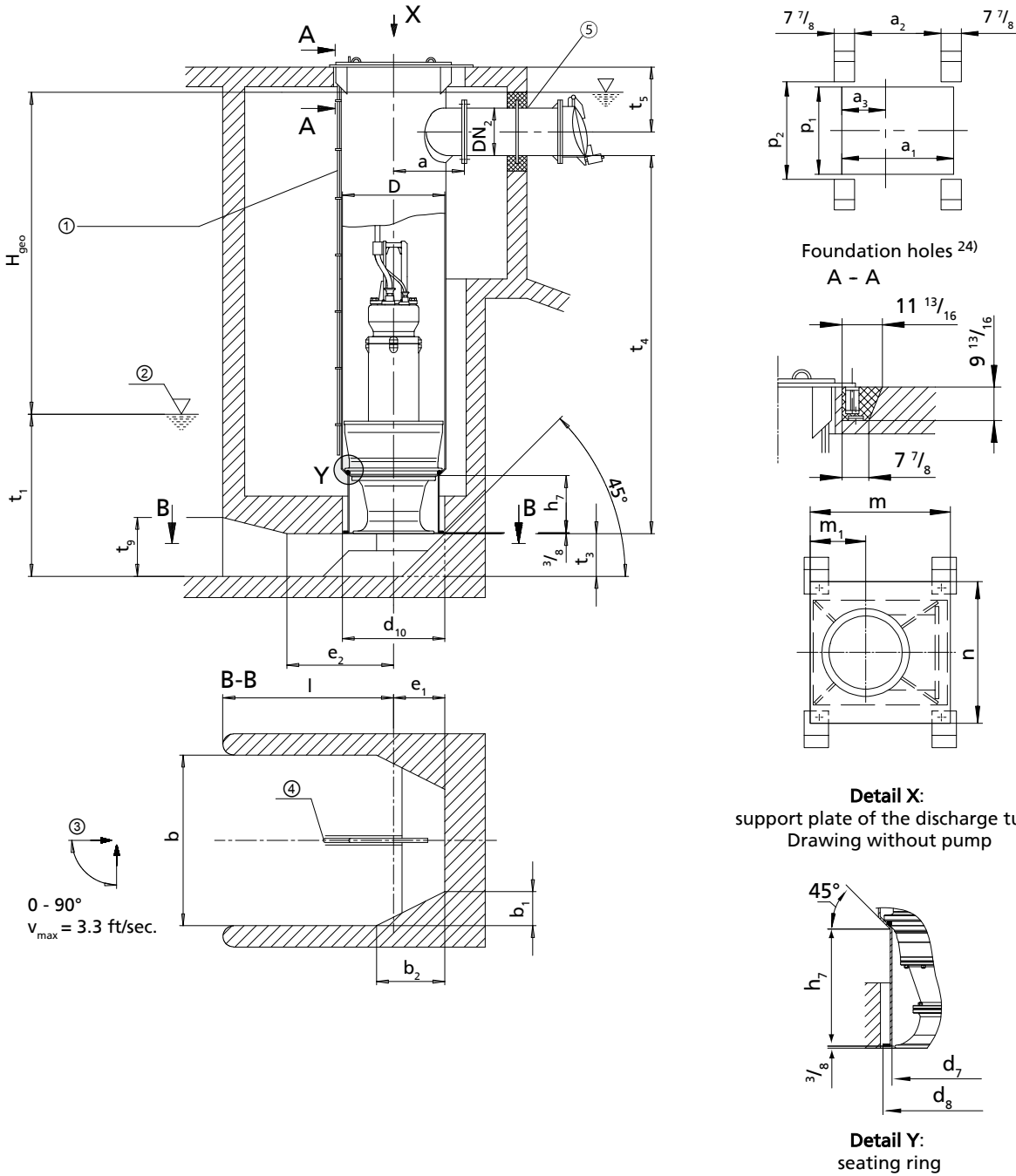

- ① Vent line
- ② Minimum water level (values see diagram on the next page)
- ③ Approach flow
- ④ Flow-straightening vane (⇒ Page 42)
- ⑤ Connect the discharge pipe to the discharge tube without transmitting any stresses and strains.

24) All dimensions for foundation holes apply to discharge tube design without intermediate flange.

All dimensions in [inch]

Pump size	D	DN ₂ min	DN ₂ max	a	a ₁ ²⁵⁾	a ₂ ²⁵⁾	a ₃ ²⁵⁾	b	b ₁	b ₂	d ₇	d ₈	d ₁₀
650-364	26	15 3/4	23 5/8	24	41 5/16	31 1/2	15 15/16	39 3/8	7 7/8	15 3/4	20 7/8	21 5/8	23 5/8
650-365	26	15 3/4	23 5/8	24	41 5/16	31 1/2	15 15/16	39 3/8	7 7/8	15 3/4	20 7/8	21 5/8	23 5/8
650-404	26	15 3/4	23 5/8	24	41 5/16	31 1/2	15 15/16	39 3/8	7 7/8	15 3/4	20 7/8	21 5/8	23 5/8
650-405	26	15 3/4	23 5/8	24	41 5/16	31 1/2	15 15/16	49 3/16	9 13/16	19 11/16	20 7/8	26	27 3/16
800-505	32	19 11/16	31 1/2	27 9/16	48 1/16	38 3/16	18 7/8	49 3/16	9 13/16	19 11/16	26 3/4	27 9/16	28 15/16

All dimensions in [inch]

Pump size	e ₁ ²⁶⁾	e ₂	h ₇	l _{min}	m ²⁵⁾	m ₁ ²⁵⁾	n ²⁵⁾	p ₁ ²⁵⁾	p ₂ ²⁵⁾	t ₃ ²⁶⁾	t ₄ min ²⁷⁾	t ₅ min ²⁵⁾	t ₉
650-364	11 13/16	19 11/16	8 7/8	39 3/8	43 5/16	16 15/16	45 11/16	33 7/8	37 13/16	10 1/4	92 1/2	28 3/8	14 3/4
650-365	11 13/16	19 11/16	8 7/8	39 3/8	43 5/16	16 15/16	45 11/16	33 7/8	37 13/16	10 1/4	92 1/2	28 3/8	14 3/4
650-404	11 13/16	19 11/16	10 7/16	39 3/8	43 5/16	16 15/16	45 11/16	33 7/8	37 13/16	10 1/4	102 3/8	28 3/8	14 3/4
650-405	14 3/4	24 5/8	10 7/16	49 3/16	43 5/16	16 15/16	45 11/16	33 7/8	37 13/16	12 5/8	108 1/4	28 3/8	18 1/2
800-505	14 3/4	24 5/8	13 3/16	49 3/16	50	19 7/8	54 1/8	42 5/16	46 1/4	12 5/8	106 5/16	32 7/8	18 1/2

Permissible tolerances:

- Tolerances in building construction to DIN 18202, Part 4, Group B
- Welded constructions: B/F to DIN EN ISO 13920
- Tolerances for conical seat (detail Y): ISO 2768-mH
- Discharge flanges to DIN EN 1092-1 PN6, DIN EN 1092-2 PN6

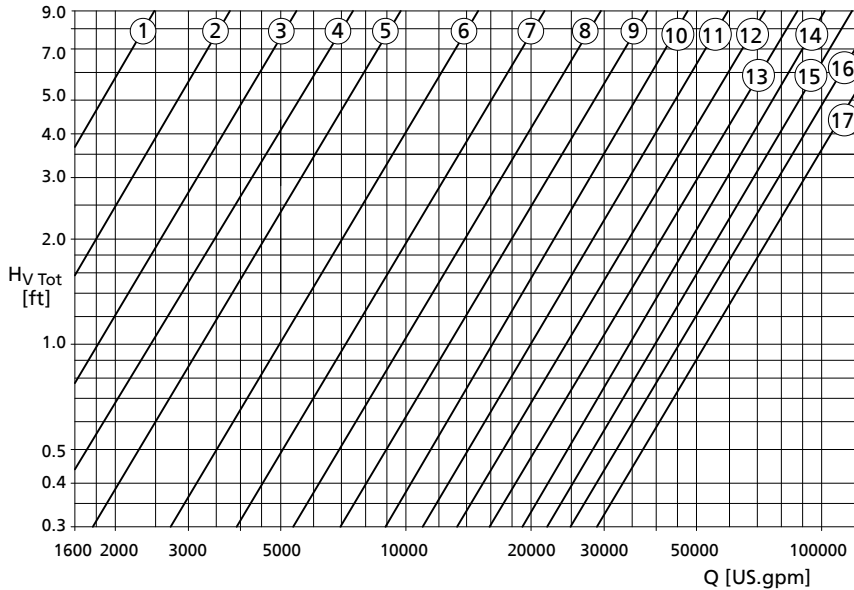
Loss diagram

- ① - DN₂ = 7 7/8 inch
- ② - DN₂ = 9 13/16 inch
- ③ - DN₂ = 11 13/16 inch
- ④ - DN₂ = 13 3/4 inch
- ⑤ - DN₂ = 15 3/4 inch
- ⑥ - DN₂ = 19 11/16 inch

- ⑦ - DN₂ = 23 5/8 inch
- ⑧ - DN₂ = 27 9/16 inch
- ⑨ - DN₂ = 31 1/2 inch
- ⑩ - DN₂ = 35 7/16 inch
- ⑪ - DN₂ = 39 3/8 inch
- ⑫ - DN₂ = 43 5/16 inch

- ⑬ - DN₂ = 47 1/4 inch
- ⑭ - DN₂ = 51 3/16 inch
- ⑮ - DN₂ = 55 1/8 inch
- ⑯ - DN₂ = 59 1/16 inch
- ⑰ - DN₂ = 63 inch

Calculation formulas:

- 25) Selected for DN₂ max.
- 26) Always observe this dimension.
- 27) Value for maximum motor length

$$H = H_{geo} + \Delta H_v$$

ΔH_v

- Loss in the riser (pipe friction)
- $H_{v, ges.}$ (see diagram)

$H_{v, ges.}$ comprises:

- Elbow
- Discharge pipe length = $5 \times DN_2$
- Swing check valve
- Outlet losses $v^2/2g$

Diagram for minimum water level t₁

Covered chamber

t₁ [inch]

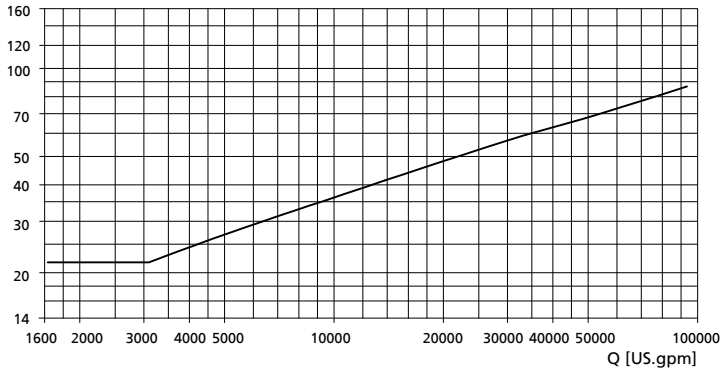

Minimum water level

Example of installation type CG (Amacan S 800 - 535 to 1300 - 820)

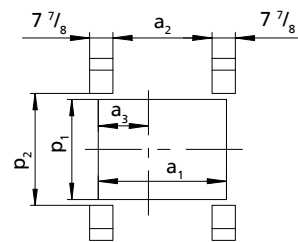
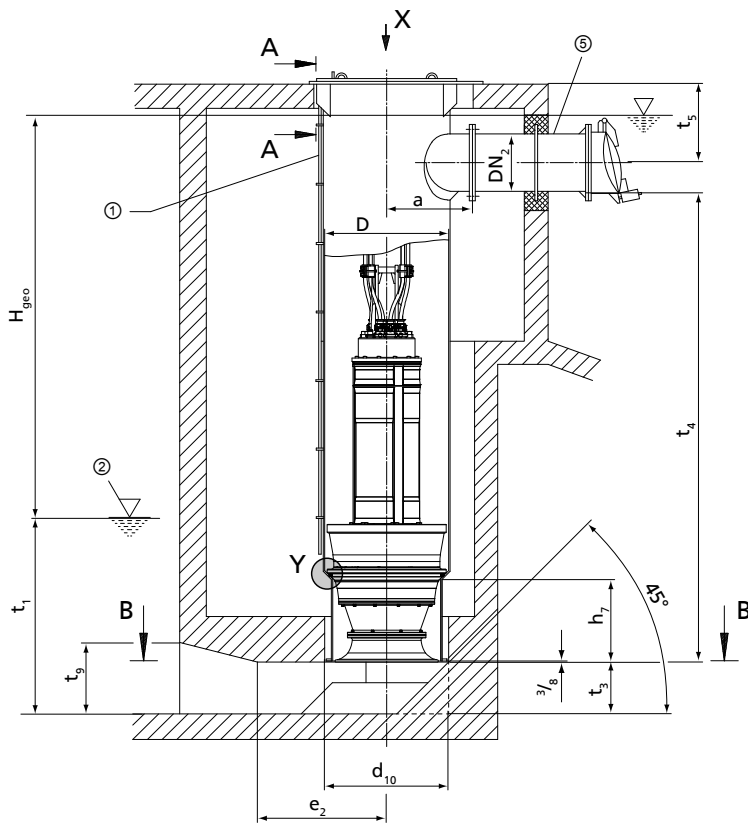

Foundation holes ²⁸⁾

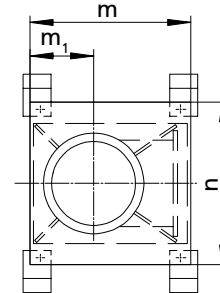
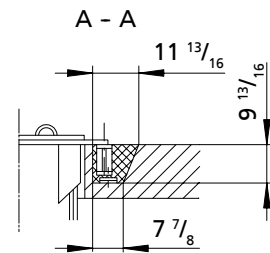

Detail X:

support plate of the discharge tube
Drawing without pump

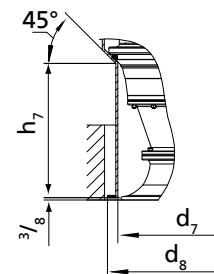

Detail Y:

seating ring

B - B

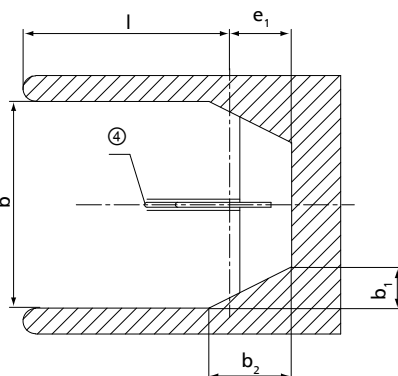

0 - 90°
 $v_{max} = 3.3 \text{ ft/sec.}$

- ① Vent line
- ② Minimum water level (values see diagram on the next page)
- ③ Approach flow
- ④ Flow-straightening vane (⇒ Page 42)
- ⑤ Connect the discharge pipe to the discharge tube without transmitting any stresses and strains.

All dimensions in [inch]

Pump size	D	DN ₂ min	DN ₂ max	a	a ₁ ²⁹⁾	a ₂ ²⁹⁾	a ₃ ²⁹⁾	b	b ₁	b ₂	d ₇	d ₈	d ₁₀
800 - 535	32	19 11/16	31 1/2	27 9/16	48 1/16	38 3/16	18 7/8	59 1/16	11 13/16	23 5/8	28 3/8	33 1/16	34 13/16
850 - 550	34 3/16	19 11/16	31 1/2	28 3/4	50 3/16	40 3/16	19 7/8	59 1/16	11 13/16	23 5/8	29 1/8	33 1/16	34 13/16
900 - 600	36	23 5/8	35 7/16	29 15/16	51 15/16	42 1/8	20 7/8	59 1/16	11 13/16	23 5/8	31 1/2	32 5/16	33 7/8

Pump size	D	DN ₂ min	DN ₂ max	a	a ₁ ²⁹⁾	a ₂ ²⁹⁾	a ₃ ²⁹⁾	b	b ₁	b ₂	d ₇	d ₈	d ₁₀
900 - 615	36	23 5/8	35 7/16	29 15/16	51 15/16	42 1/8	20 7/8	70 7/8	14 3/16	28 3/8	30 11/16	35 13/16	37 5/8
900 - 620	36	23 5/8	35 7/16	29 15/16	51 15/16	42 1/8	20 7/8	49 3/16	9 13/16	19 11/16	30 5/16	31 1/8	32 11/16
1000 - 655	40	27 9/16	39 3/8	31 7/8	56 5/16	45 11/16	22 13/16	70 7/8	14 3/16	28 3/8	36 1/4	39 3/8	40 15/16
1300 - 820	51 15/16	39 3/8	51 3/16	37 13/16	67 11/16	57 7/8	28 3/8	90 9/16	18 1/8	36 1/4	42 1/2	51 3/16	53 9/16

All dimensions in [inch]

Pump size	e ₁ ³⁰⁾	e ₂	h ₇	l _{min}	m ²⁹⁾	m ₁ ²⁹⁾	n ²⁹⁾	p ₁	p ₂	t ₃ ³⁰⁾	t ₄ min ³¹⁾	t ₅ min ²⁹⁾	t ₉
800 - 535	17 11/16	29 1/2	12 13/16	59 1/16	50	19 7/8	54 1/8	42 5/16	46 1/4	14 15/16	110 1/4	32 7/8	22 7/16
850 - 550	17 11/16	29 1/2	14 3/4	59 1/16	52 3/16	20 7/8	54 1/8	42 5/16	46 1/4	14 15/16	127 15/16	32 7/8	22 7/16
900 - 600	17 11/16	29 1/2	16 5/16	59 1/16	54 5/16	22 1/16	58 1/4	46 7/16	50 3/8	14 15/16	126	36 7/16	22 7/16
900 - 615	20 1/2	35 7/16	16 9/16	70 7/8	54 5/16	22 1/16	58 1/4	46 7/16	50 3/8	17 5/16	126	36 7/16	126
900 - 620	16 5/16	24 5/8	14 3/8	49 3/16	54 5/16	22 1/16	58 1/4	46 7/16	50 3/8	12 5/8	126	36 7/16	18 1/2
1000 - 655	20 1/2	35 7/16	20 1/4	70 7/8	59 13/16	24 5/8	63 3/4	50 3/8	54 5/16	17 5/16	147 5/8	38 9/16	126
1300 - 820	26 3/4	45 1/4	21 7/16	90 9/16	71 1/4	30 1/8	77 3/16	63 3/4	67 11/16	22 1/16	153 9/16	46 7/16	33 7/16

Permissible tolerances:

- Tolerances in building construction to DIN 18202, Part 4, Group B
- Welded constructions: B/F to DIN EN ISO 13920
- Tolerances for conical seat (detail Y): ISO 2768-mH
- Discharge flanges to DIN EN 1092-1 PN6, DIN EN 1092-2 PN6

Loss diagram

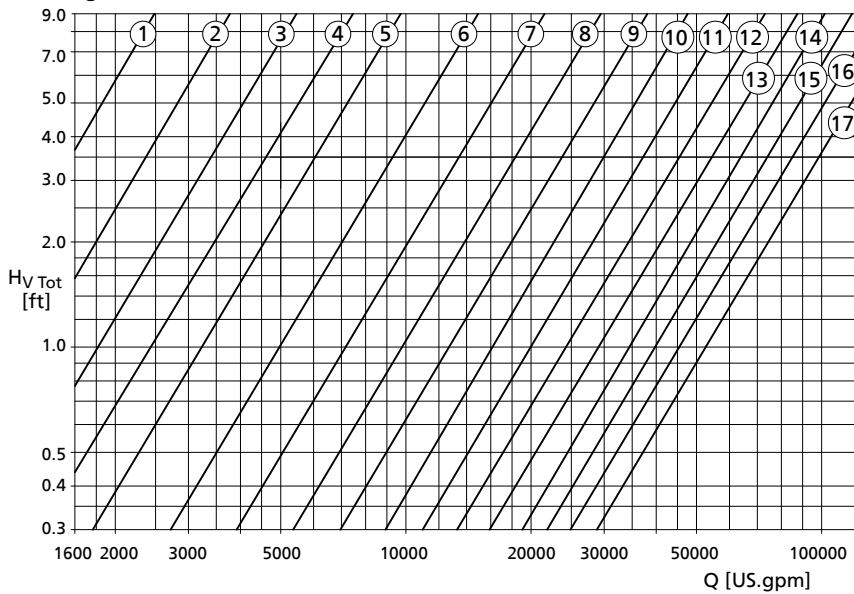

- ① - DN₂ = 7 7/8 inch
- ② - DN₂ = 9 13/16 inch
- ③ - DN₂ = 11 13/16 inch
- ④ - DN₂ = 13 3/4 inch
- ⑤ - DN₂ = 15 3/4 inch
- ⑥ - DN₂ = 19 11/16 inch

- ⑦ - DN₂ = 23 5/8 inch
- ⑧ - DN₂ = 27 9/16 inch
- ⑨ - DN₂ = 31 1/2 inch
- ⑩ - DN₂ = 35 7/16 inch
- ⑪ - DN₂ = 39 3/8 inch
- ⑫ - DN₂ = 43 5/16 inch

- ⑬ - DN₂ = 47 1/4 inch
- ⑭ - DN₂ = 51 3/16 inch
- ⑮ - DN₂ = 55 1/8 inch
- ⑯ - DN₂ = 59 1/16 inch
- ⑰ - DN₂ = 63 inch

Calculation formulas:

- 29) Selected for DN₂ max.
- 28) All dimensions for foundation holes apply to discharge tube design without intermediate flange.
- 29) Selected for DN₂ max.
- 30) Always observe this dimension.
- 31) Value for maximum motor length

$$H = H_{\text{geo}} + \Delta H_v$$

ΔH_v

- Loss in the riser (pipe friction)
- $H_{v, \text{ges.}}$ (see diagram)

$H_{v, \text{ges.}}$ comprises:

- Elbow
- Discharge pipe length = $5 \times DN_2$
- Swing check valve
- Outlet losses $v^2/2g$

Diagram for minimum water level t₁

Covered chamber

t₁ [inch]

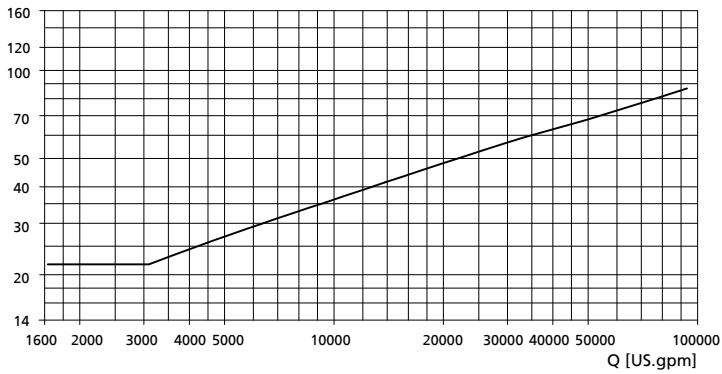

Minimum water level

Example of installation type DU (Amacan S 650 - 364 to 800 - 505)

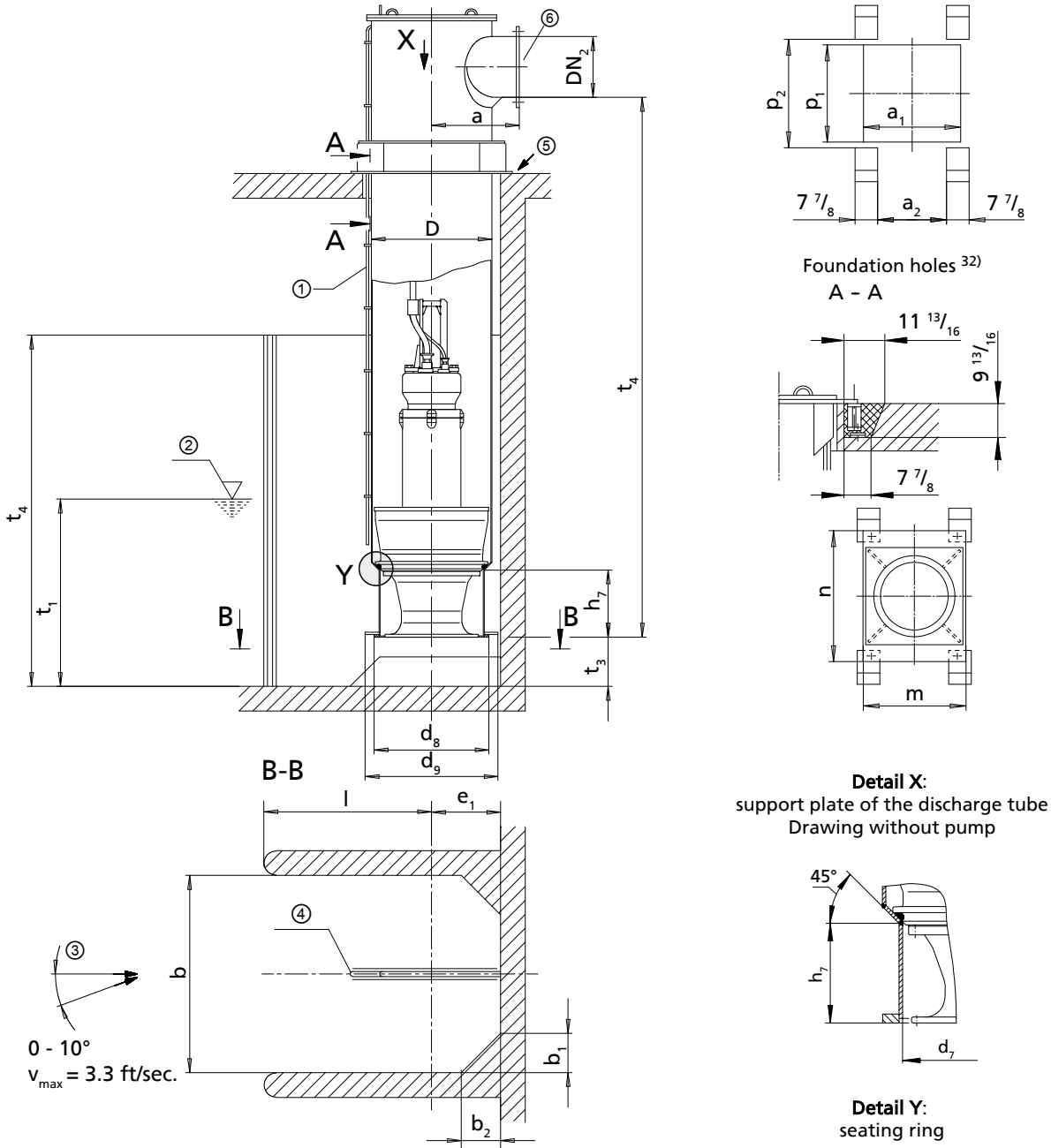

- ① Vent line
- ② Minimum water level (values see diagram on the next page)
- ③ Approach flow
- ④ Flow-straightening vane (⇒ Page 42)
- ⑤ Not pressure-proof
- ⑥ Connect the discharge pipe to the discharge tube without transmitting any stresses and strains.

32) All dimensions for foundation holes apply to discharge tube design without intermediate flange.

All dimensions in [inch]

Pump size	D	DN ₂ min	DN ₂ max	a	a ₁	a ₂	b	b ₁		b ₂		d ₇
								without suction umbrella d ₈	with suction umbrella d ₉	without suction umbrella d ₈	with suction umbrella d ₉	
650-364	26	15 3/4	23 5/8	24	31 7/8	22 1/16	39 3/8	7 7/8	–	7 7/8	–	20 7/8
650-365	26	15 3/4	23 5/8	24	31 7/8	22 1/16	39 3/8	7 7/8	–	7 7/8	–	20 7/8
650-404	26	15 3/4	23 5/8	24	31 7/8	22 1/16	39 3/8	7 7/8	–	7 7/8	–	20 7/8
650-405	26	15 3/4	23 5/8	24	31 7/8	22 1/16	49 3/16	9 13/16	–	9 13/16	–	20 7/8
800-505	32	19 11/16	31 1/2	27 9/16	37 13/16	27 15/16	49 3/16	9 13/16	–	9 13/16	–	26 3/4

All dimensions in [inch]

Pump size	d ₈	d ₉	e ₁ ³³⁾		h ₇	l _{min}	m	n	p ₁	p ₂	t ₃ ³³⁾	t ₄ min ³⁴⁾
			without suction umbrella d ₈	with suction umbrella d ₉								
650-364	26	35 7/16	16 9/16	21 1/4	8 7/8	22 13/16	33 7/8	43 11/16	31 7/8	35 13/16	10 1/4	92 1/2
650-365	26	35 7/16	16 9/16	21 1/4	8 7/8	22 13/16	33 7/8	43 11/16	31 7/8	35 13/16	10 1/4	92 1/2
650-404	26	35 7/16	16 9/16	21 1/4	10 7/16	22 13/16	33 7/8	43 11/16	31 7/8	35 13/16	10 1/4	102 3/8
650-405	26	35 7/16	16 9/16	21 1/4	10 7/16	22 13/16	33 7/8	43 11/16	31 7/8	35 13/16	10 5/8	108 1/4
800-505	31 7/8	41 5/16	19 11/16	24 7/16	13 3/16	29 1/2	40 9/16	49 5/8	37 13/16	41 3/4	10 5/8	106 5/16

 $t_2 = 1.1 \times \text{water level}; \text{max. } 2 \times t_1 \text{ (depending on head H and structure)}$

 Height of corner lining (b₁ and b₂) like t₂

Permissible tolerances:

- Tolerances in building construction to DIN 18202, Part 4, Group B
- Welded constructions: B/F to DIN EN ISO 13920
- Tolerances for conical seat (detail Y): ISO 2768-mH
- Discharge flanges to DIN EN 1092-1 PN6, DIN EN 1092-2 PN6

³³⁾ Always observe this dimension.

³⁴⁾ Value for maximum motor length

Loss diagram

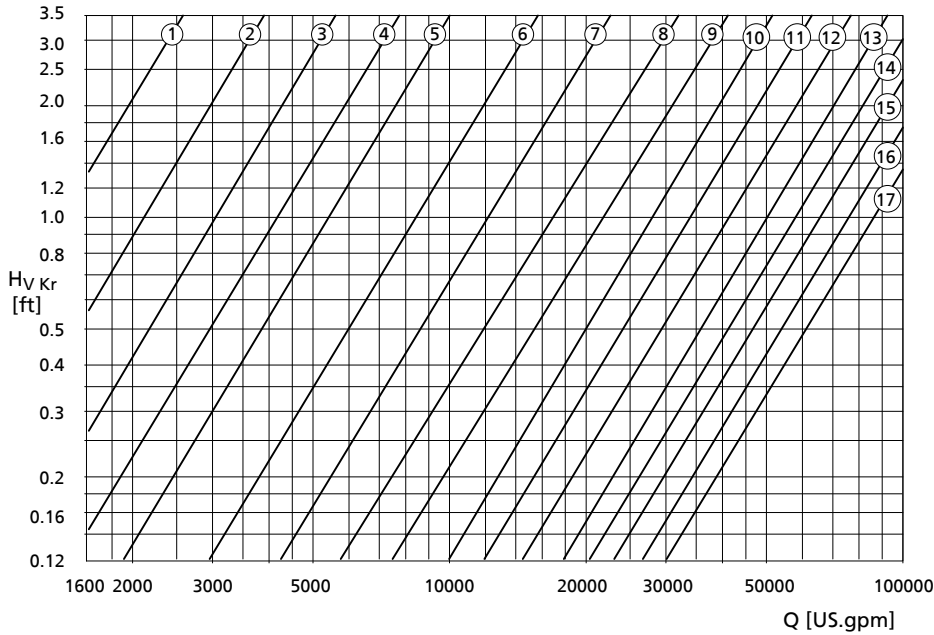

- ① - DN₂ = 7 7/8 inch
- ② - DN₂ = 9 13/16 inch
- ③ - DN₂ = 11 13/16 inch
- ④ - DN₂ = 13 3/4 inch
- ⑤ - DN₂ = 15 3/4 inch
- ⑥ - DN₂ = 19 11/16 inch

- ⑦ - DN₂ = 23 5/8 inch
- ⑧ - DN₂ = 27 9/16 inch
- ⑨ - DN₂ = 31 1/2 inch
- ⑩ - DN₂ = 35 7/16 inch
- ⑪ - DN₂ = 39 3/8 inch
- ⑫ - DN₂ = 43 5/16 inch

- ⑬ - DN₂ = 47 1/4 inch
- ⑭ - DN₂ = 51 3/16 inch
- ⑮ - DN₂ = 55 1/8 inch
- ⑯ - DN₂ = 59 1/16 inch
- ⑰ - DN₂ = 63 inch

Calculation formulas:

$$H = H_{\text{geo}} + \Delta H_v$$

ΔH_v

- Loss in the elbow $h_{v, Kr}$ (see diagram)
- Loss in the riser (pipe friction)
- $H_{v, \text{System}}$ (valves, etc.)

$H_{v, \text{System}}$ must be determined for the specific system.

Diagram for minimum water level t₁

Open chamber

t₁ [inch]

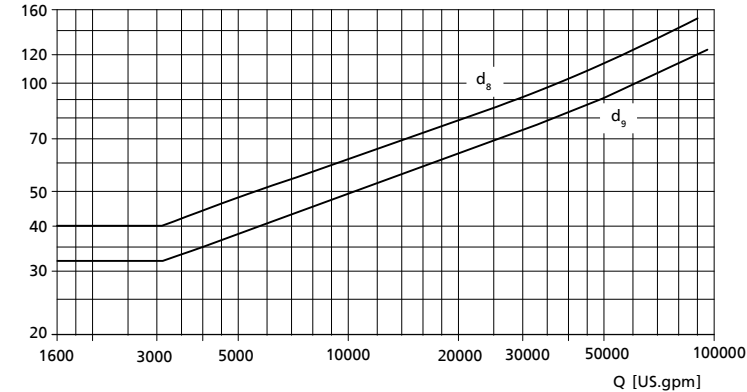

Minimum water level

d_8 = Design: **without** suction umbrella (standard)

d_9 = Design: **with** suction umbrella

Example of installation type DU (Amacan S 800 - 535 to 1300 - 820)

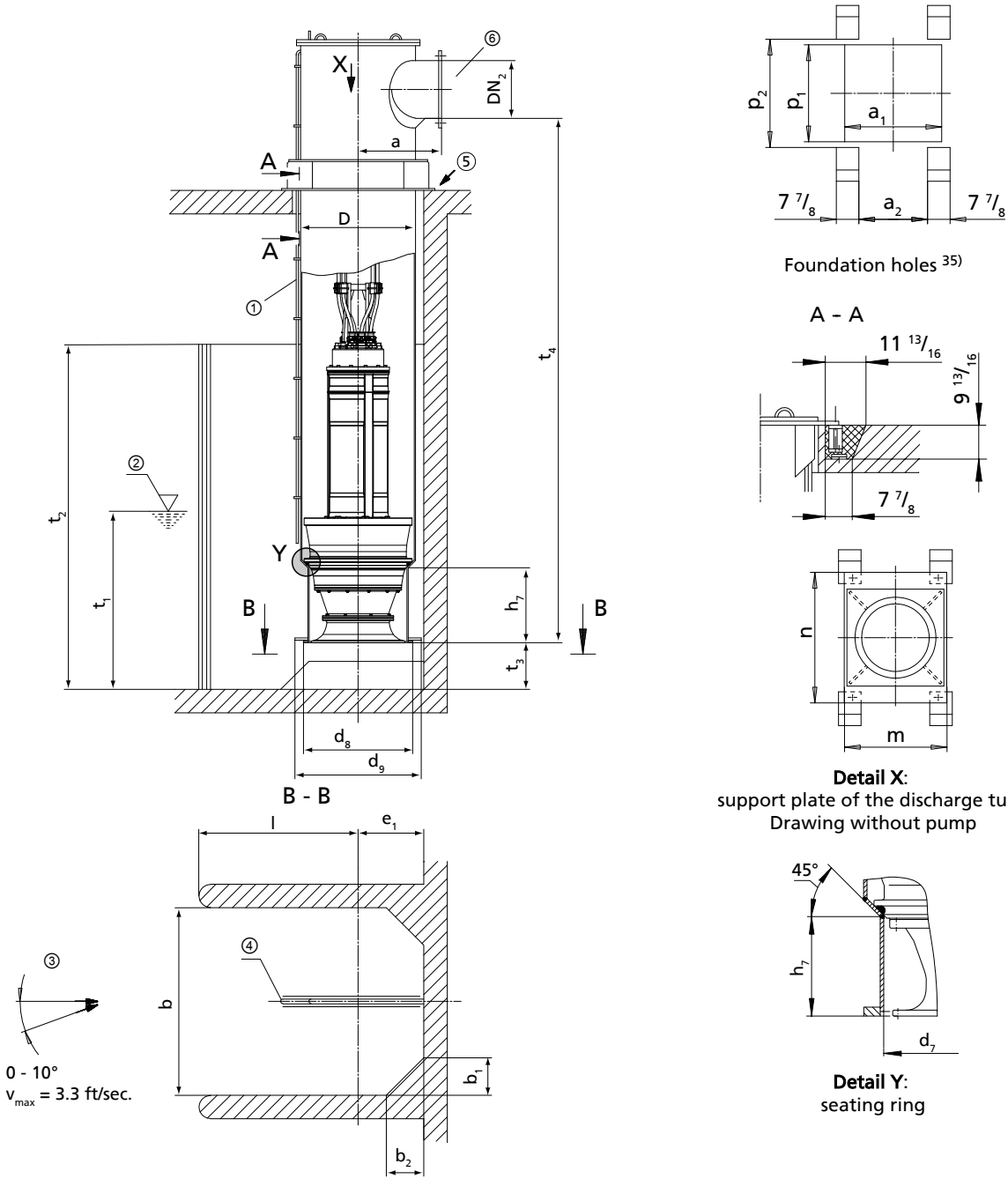

- ① Vent line
- ② Minimum water level (values see diagram on the next page)
- ③ Approach flow
- ④ Flow-straightening vane (⇒ Page 42)
- ⑤ Not pressure-proof
- ⑥ Connect the discharge pipe to the discharge tube without transmitting any stresses and strains.

35) All dimensions for foundation holes apply to discharge tube design without intermediate flange.

All dimensions in [inch]

Pump size	D	DN ₂ min	DN ₂ max	a	a ₁	a ₂	b	b ₁		b ₂		d ₇
								without suction umbrella d ₈	with suction umbrella d ₉	without suction umbrella d ₈	with suction umbrella d ₉	
800 - 535	32	19 11/16	31 1/2	27 9/16	37 13/16	27 15/16	59 1/16	11 13/16	–	11 13/16	–	28 3/8
850 - 550	34 3/16	19 11/16	31 1/2	28 3/4	39 3/4	29 15/16	59 1/16	11 13/16	–	11 13/16	–	29 1/8
900 - 600	36	23 5/8	35 7/16	29 15/16	41 3/4	31 7/8	59 1/16	11 13/16	–	11 13/16	–	31 1/2
900 - 615	36	23 5/8	35 7/16	29 15/16	41 3/4	31 7/8	70 7/8	14 3/16	–	14 3/16	–	30 11/16
900 - 620	36	23 5/8	35 7/16	29 15/16	41 3/4	31 7/8	49 3/16	9 13/16	–	9 13/16	–	30 5/16
1000 - 655	40	27 9/16	39 3/8	31 7/8	45 11/16	35 13/16	70 7/8	14 3/16	–	14 3/16	–	36 1/4
1300 - 820	51 15/16	39 3/8	51 3/16	37 13/16	57 1/2	47 5/8	90 9/16	18 1/8	–	18 1/8	–	42 1/2

All dimensions in [inch]

Pump size	d ₈	d ₉	e ₁ ³⁶⁾		h ₇	l _{min}	m	n	p ₁	p ₂	t ₃ ³⁶⁾	t _{4 min} ³⁷⁾
			without suction umbrella d ₈	with suction umbrella d ₉								
800 - 535	31 7/8	51 3/16	19 11/16	29 1/2	12 13/16	39 3/8	40 9/16	49 5/8	37 13/16	41 3/4	14 15/16	110 1/4
850 - 550	34 1/16	51 3/16	20 11/16	29 1/2	14 3/4	38 3/8	42 1/2	51 9/16	39 3/4	43 11/16	14 15/16	127 15/16
900 - 600	35 13/16	51 3/16	21 5/8	29 1/2	16 5/16	37 3/8	44 1/2	53 9/16	41 3/4	45 11/16	14 15/16	126
900 - 615	35 13/16	51 3/16	21 5/8	29 1/2	16 9/16	49 3/16	44 1/2	53 9/16	41 3/4	45 11/16	17 5/16	126
900 - 620	35 13/16	41 5/16	21 5/8	24 7/16	14 3/8	27 9/16	44 1/2	53 9/16	41 3/4	45 11/16	12 5/8	126
1000 - 655	39 15/16	59 1/16	23 5/8	33 7/16	20 1/4	47 1/2	48 13/16	59 1/16	45 11/16	49 5/8	17 5/16	147 5/8
1300 - 820	51 15/16	70 7/8	29 1/2	39 3/8	21 7/16	61	60 5/8	70 7/8	57 1/2	61 7/16	22 1/16	153 9/16

 $t_2 = 1.1 \times \text{water level}$; max. $2 \times t_1$ (depending on head H and structure)

 Height of corner lining (b₁ and b₂) like t₂

Permissible tolerances:

- Tolerances in building construction to DIN 18202, Part 4, Group B
- Welded constructions: B/F to DIN EN ISO 13920
- Tolerances for conical seat (detail Y): ISO 2768-mH
- Discharge flanges to DIN EN 1092-1 PN6, DIN EN 1092-2 PN6

³⁶⁾ Always observe this dimension.

³⁷⁾ Value for maximum motor length

Loss diagram

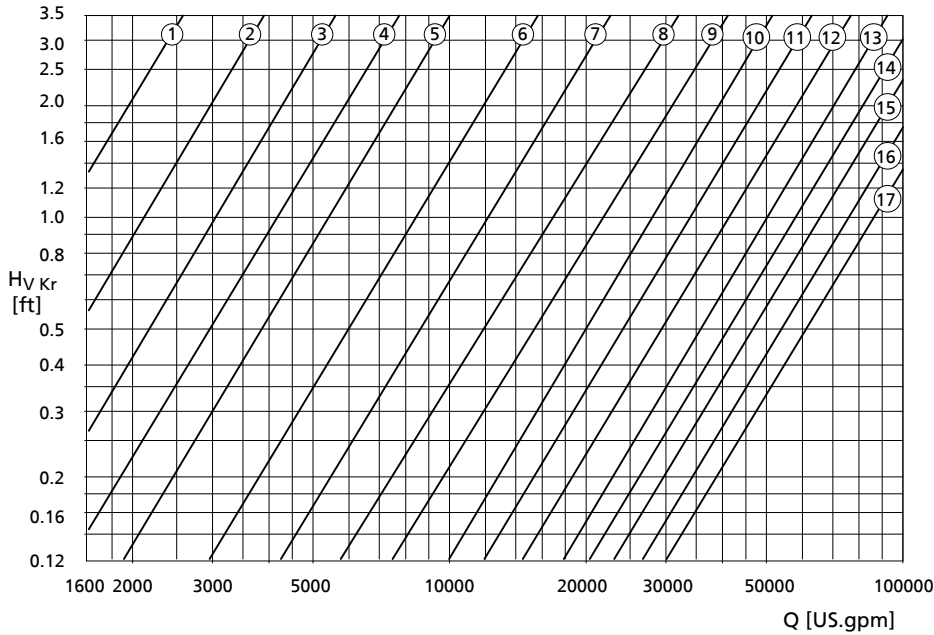

- | | | |
|-------------------------------------|------------------------------------|------------------------------------|
| ① - DN ₂ = 7 7/8 inch | ⑦ - DN ₂ = 23 5/8 inch | ⑬ - DN ₂ = 47 1/4 inch |
| ② - DN ₂ = 9 13/16 inch | ⑧ - DN ₂ = 27 9/16 inch | ⑭ - DN ₂ = 51 3/16 inch |
| ③ - DN ₂ = 11 13/16 inch | ⑨ - DN ₂ = 31 1/2 inch | ⑮ - DN ₂ = 55 1/8 inch |
| ④ - DN ₂ = 13 3/4 inch | ⑩ - DN ₂ = 35 7/16 inch | ⑯ - DN ₂ = 59 1/16 inch |
| ⑤ - DN ₂ = 15 3/4 inch | ⑪ - DN ₂ = 39 3/8 inch | ⑰ - DN ₂ = 63 inch |
| ⑥ - DN ₂ = 19 11/16 inch | ⑫ - DN ₂ = 43 5/16 inch | |

Calculation formulas:

$$H = H_{\text{geo}} + \Delta H_v$$

ΔH_v

- Loss in the elbow $h_{v, Kr}$ (see diagram)
- Loss in the riser (pipe friction)
- $H_{v, \text{System}}$ (valves, etc.)

$H_{v, \text{System}}$ must be determined for the specific system.

Diagram for minimum water level t_1

Open chamber

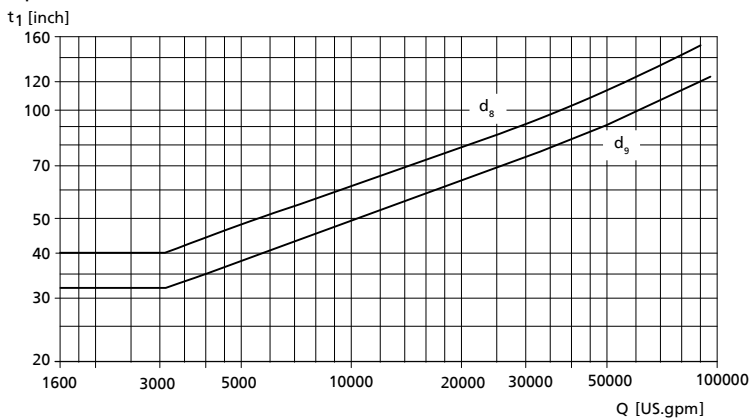

Minimum water level

d_8 = Design: **without** suction umbrella (standard)

d_9 = Design: **with** suction umbrella

Example of installation type DG (Amacan S 650 - 364 to 800 - 505)

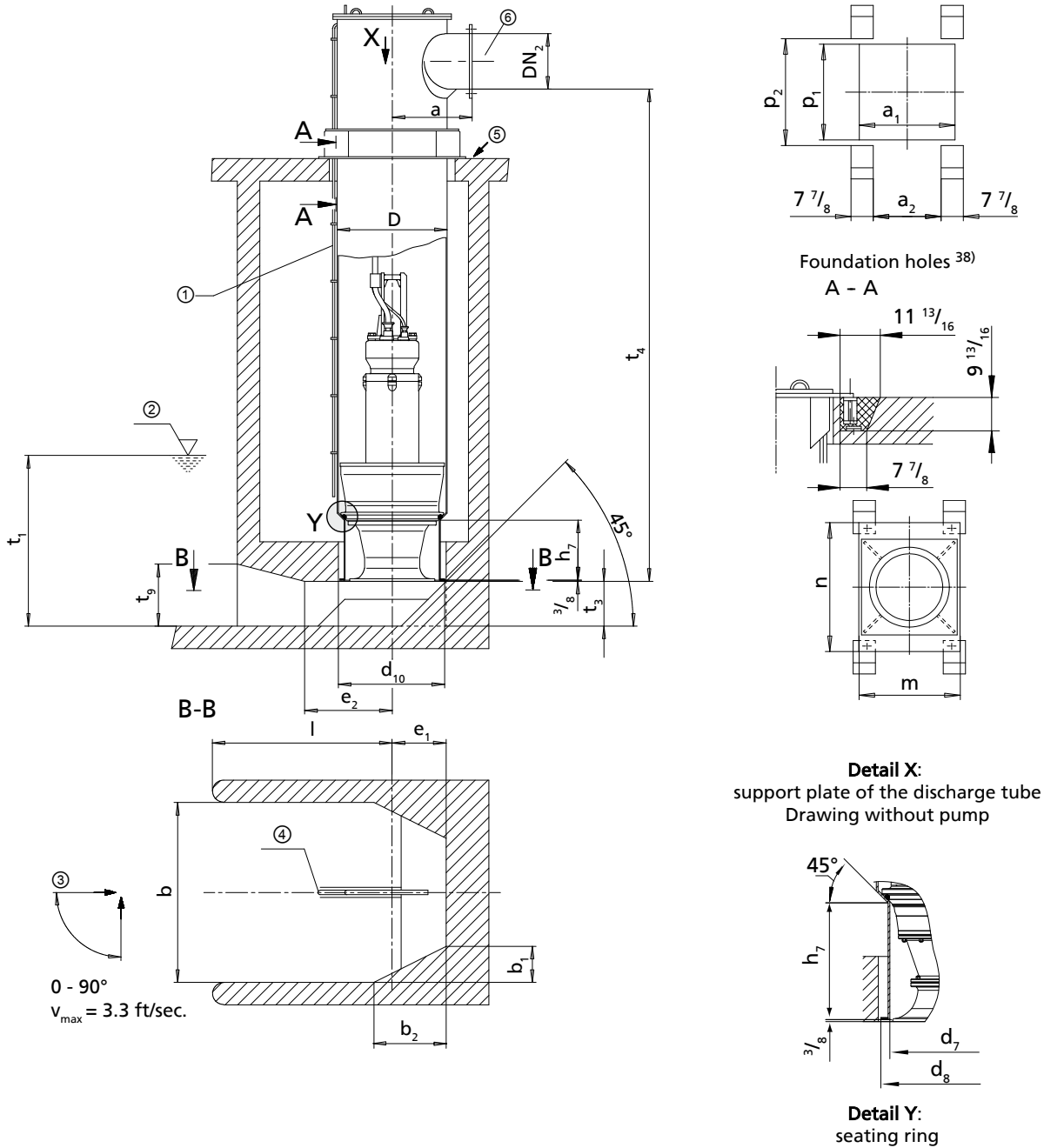

- ① Vent line
- ② Minimum water level (values see diagram on the next page)
- ③ Approach flow
- ④ Flow-straightening vane (⇒ Page 42)
- ⑤ Not pressure-proof
- ⑥ Connect the discharge pipe to the discharge tube without transmitting any stresses and strains.

38) All dimensions for foundation holes apply to discharge tube design without intermediate flange.

All dimensions in [inch]

Pump size	D	DN ₂ min	DN ₂ max	a	a ₁	a ₂	b	b ₁	b ₂	d ₇	d ₈	d ₁₀
650-364	26	15 3/4	23 5/8	24	31 7/8	22 1/16	39 3/8	7 7/8	15 3/4	20 7/8	21 5/8	23 5/8
650-365	26	15 3/4	23 5/8	24	31 7/8	22 1/16	39 3/8	7 7/8	15 3/4	20 7/8	21 5/8	23 5/8
650-404	26	15 3/4	23 5/8	24	31 7/8	22 1/16	39 3/8	7 7/8	15 3/4	20 7/8	21 5/8	23 5/8
650-405	26	15 3/4	23 5/8	24	31 7/8	22 1/16	49 3/16	9 13/16	19 11/16	20 7/8	26	26
800-505	32	19 11/16	31 1/2	27 9/16	37 13/16	27 15/16	49 3/16	9 13/16	19 11/16	26 3/4	27 9/16	27 9/16

All dimensions in [inch]

Pump size	e ₁ ³⁹⁾	e ₂	h ₇	l _{min}	m	n	p ₁	p ₂	t ₃ ³⁹⁾	t ₄ min ⁴⁰⁾	t ₉
650-364	11 13/16	19 11/16	8 7/8	39 3/8	33 7/8	43 11/16	31 7/8	35 13/16	10 1/4	92 1/2	14 3/4
650-365	11 13/16	19 11/16	8 7/8	39 3/8	33 7/8	43 11/16	31 7/8	35 13/16	10 1/4	92 1/2	14 3/4
650-404	11 13/16	19 11/16	10 7/16	39 3/8	33 7/8	43 11/16	31 7/8	35 13/16	10 1/4	102 3/8	14 3/4
650-405	14 3/4	24 5/8	10 7/16	49 3/16	33 7/8	43 11/16	31 7/8	35 13/16	12 5/8	108 1/4	18 1/2
800-505	14 3/4	24 5/8	13 3/16	49 3/16	40 9/16	49 5/8	37 13/16	41 3/4	12 5/8	106 5/16	18 1/2

Permissible tolerances:

- Tolerances in building construction to DIN 18202, Part 4, Group B
- Welded constructions: B/F to DIN EN ISO 13920
- Tolerances for conical seat (detail Y): ISO 2768-mH
- Discharge flanges to DIN EN 1092-1 PN6, DIN EN 1092-2 PN6

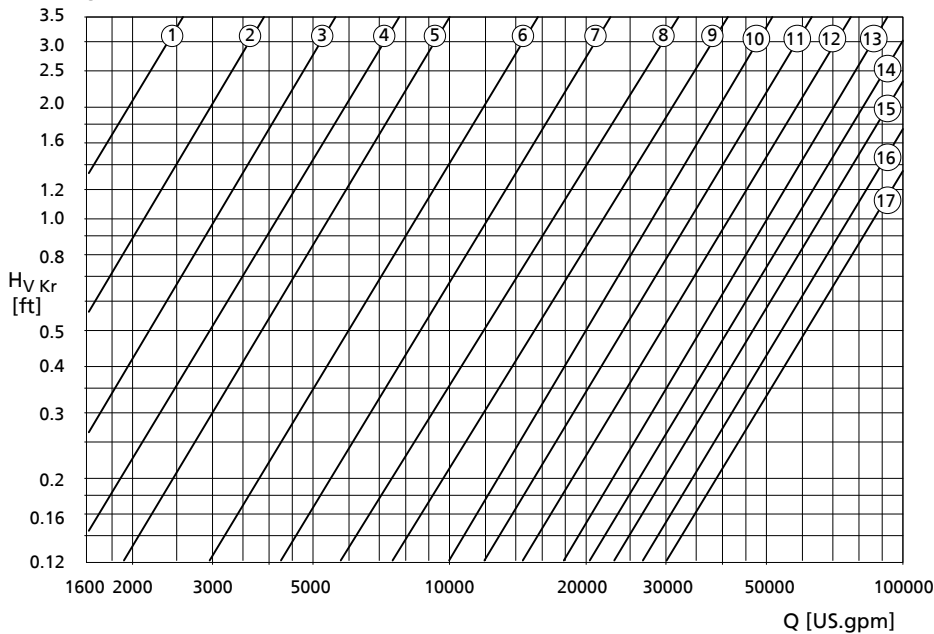
Loss diagram

- ① - DN₂ = 7 7/8 inch
- ② - DN₂ = 9 13/16 inch
- ③ - DN₂ = 11 13/16 inch
- ④ - DN₂ = 13 3/4 inch
- ⑤ - DN₂ = 15 3/4 inch
- ⑥ - DN₂ = 19 11/16 inch

- ⑦ - DN₂ = 23 5/8 inch
- ⑧ - DN₂ = 27 9/16 inch
- ⑨ - DN₂ = 31 1/2 inch
- ⑩ - DN₂ = 35 7/16 inch
- ⑪ - DN₂ = 39 3/8 inch
- ⑫ - DN₂ = 43 5/16 inch

- ⑬ - DN₂ = 47 1/4 inch
- ⑭ - DN₂ = 51 3/16 inch
- ⑮ - DN₂ = 55 1/8 inch
- ⑯ - DN₂ = 59 1/16 inch
- ⑰ - DN₂ = 63 inch

39) Always observe this dimension.

40) Value for maximum motor length

Calculation formulas:

$$H = H_{\text{geo}} + \Delta H_v$$

ΔH_v

- Loss in the elbow $h_{V_{Kr}}$ (see diagram)
- Loss in the riser (pipe friction)
- $H_{V_{\text{System}}}$ (valves, etc.)

$H_{V_{\text{System}}}$ must be determined for the specific system.

Diagram for minimum water level t_1

Covered chamber

t_1 [inch]

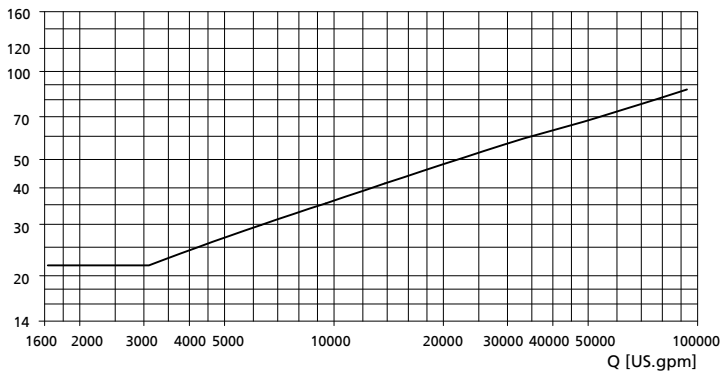

Minimum water level

Example of installation type DG (Amacan S 800 - 535 to 1300 - 820)

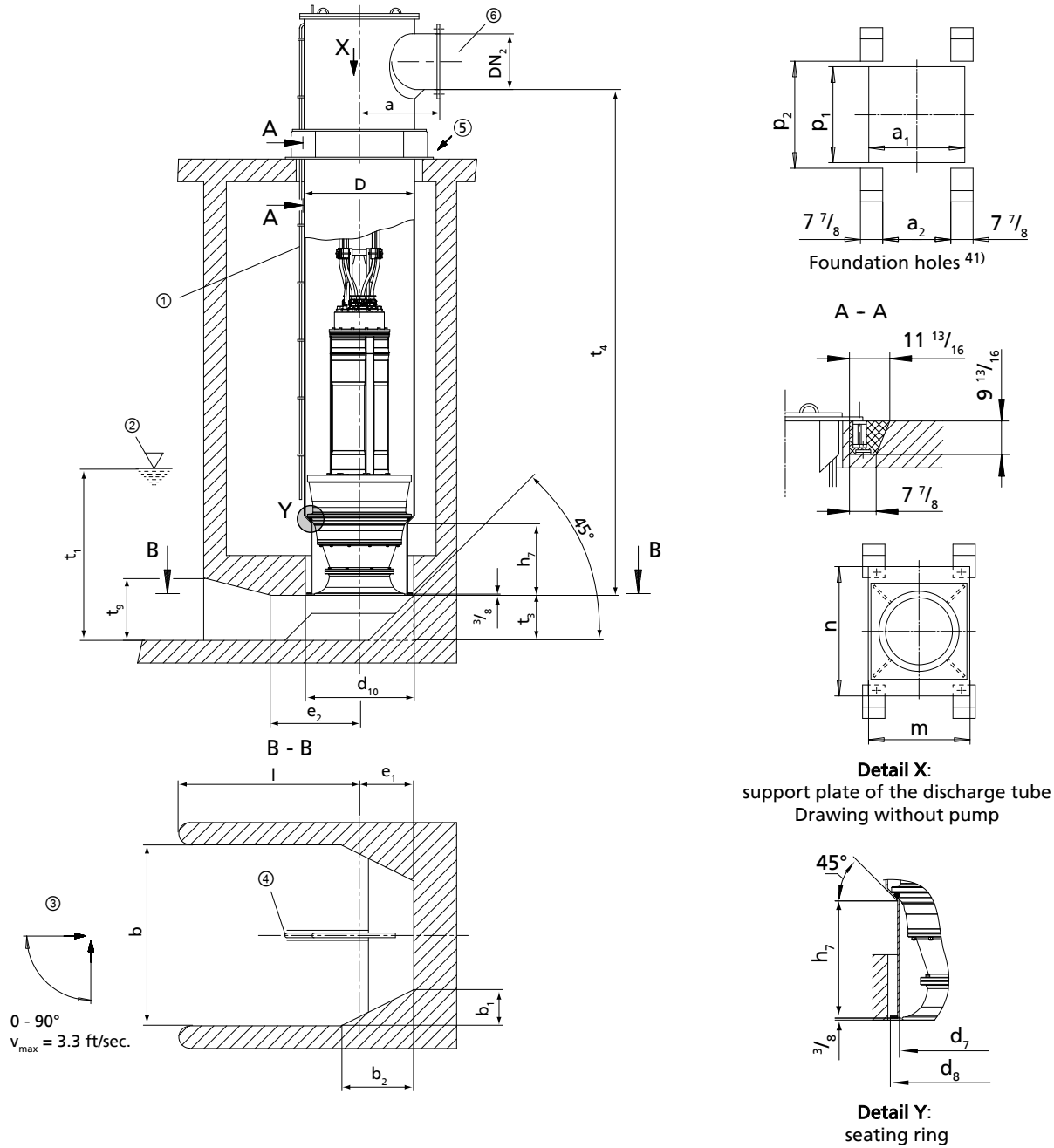

- ① Vent line
- ② Minimum water level (values see diagram on the next page)
- ③ Approach flow
- ④ Flow-straightening vane (⇒ Page 42)
- ⑤ Not pressure-proof
- ⑥ Connect the discharge pipe to the discharge tube without transmitting any stresses and strains.

All dimensions in [inch]

Pump size	D	DN ₂ min	DN ₂ max	a	a ₁	a ₂	b	b ₁	b ₂	d ₇	d ₈	d ₁₀
800 - 535	32	19 11/16	31 1/2	27 9/16	37 13/16	27 15/16	59 1/16	11 13/16	23 5/8	28 3/8	33 1/16	34 13/16
850 - 550	34 3/16	19 11/16	31 1/2	28 3/4	39 3/4	29 15/16	59 1/16	11 13/16	23 5/8	29 1/8	33 1/16	34 13/16
900 - 600	36	23 5/8	35 7/16	29 15/16	41 3/4	31 7/8	59 1/16	11 13/16	23 5/8	31 1/2	32 5/16	33 7/8
900 - 615	36	23 5/8	35 7/16	29 15/16	41 3/4	31 7/8	70 7/8	14 3/16	28 3/8	30 11/16	35 13/16	37 5/8

41) All dimensions for foundation holes apply to discharge tube design without intermediate flange.

Pump size	D	DN ₂ min	DN ₂ max	a	a ₁	a ₂	b	b ₁	b ₂	d ₇	d ₈	d ₁₀
900 - 620	36	23 ⁵ / ₈	35 ⁷ / ₁₆	29 ¹⁵ / ₁₆	41 ³ / ₄	31 ⁷ / ₈	49 ³ / ₁₆	9 ¹³ / ₁₆	19 ¹¹ / ₁₆	30 ⁵ / ₁₆	31 ¹ / ₈	32 ¹¹ / ₁₆
1000 - 655	40	27 ⁹ / ₁₆	39 ³ / ₈	31 ⁷ / ₈	45 ¹¹ / ₁₆	35 ¹³ / ₁₆	70 ⁷ / ₈	14 ³ / ₁₆	28 ³ / ₈	36 ¹ / ₄	39 ³ / ₈	40 ¹⁵ / ₁₆
1300 - 820	51 ¹⁵ / ₁₆	39 ³ / ₈	51 ³ / ₁₆	37 ¹³ / ₁₆	57 ¹ / ₂	47 ⁵ / ₈	90 ⁹ / ₁₆	18 ¹ / ₈	36 ¹ / ₄	42 ¹ / ₂	51 ³ / ₁₆	53 ⁹ / ₁₆

All dimensions in [inch]

Pump size	e ₁ ⁴²⁾	e ₂	h ₇	l _{min}	m	n	p ₁	p ₂	t ₃ ⁴²⁾	t _{4 min} ⁴³⁾	t ₉
800 - 535	17 ¹¹ / ₁₆	29 ¹ / ₂	12 ¹³ / ₁₆	59 ¹ / ₁₆	40 ⁹ / ₁₆	49 ⁵ / ₈	37 ¹³ / ₁₆	41 ³ / ₄	14 ¹⁵ / ₁₆	110 ¹ / ₄	22 ⁷ / ₁₆
850 - 550	17 ¹¹ / ₁₆	29 ¹ / ₂	14 ³ / ₄	59 ¹ / ₁₆	42 ¹ / ₂	51 ⁹ / ₁₆	39 ³ / ₄	43 ¹¹ / ₁₆	14 ¹⁵ / ₁₆	127 ¹⁵ / ₁₆	22 ⁷ / ₁₆
900 - 600	17 ¹¹ / ₁₆	29 ¹ / ₂	16 ⁵ / ₁₆	59 ¹ / ₁₆	44 ¹ / ₂	53 ⁹ / ₁₆	41 ³ / ₄	45 ¹¹ / ₁₆	14 ¹⁵ / ₁₆	126	22 ⁷ / ₁₆
900 - 615	20 ¹ / ₂	35 ⁷ / ₁₆	16 ⁹ / ₁₆	70 ⁷ / ₈	44 ¹ / ₂	53 ⁹ / ₁₆	41 ³ / ₄	45 ¹¹ / ₁₆	17 ⁵ / ₁₆	126	26
900 - 620	16 ⁵ / ₁₆	24 ⁵ / ₈	14 ³ / ₈	49 ³ / ₁₆	44 ¹ / ₂	53 ⁹ / ₁₆	41 ³ / ₄	45 ¹¹ / ₁₆	12 ⁵ / ₈	126	18 ¹ / ₂
1000 - 655	20 ¹ / ₂	35 ⁷ / ₁₆	20 ¹ / ₄	70 ⁷ / ₈	48 ¹³ / ₁₆	59 ¹ / ₁₆	45 ¹¹ / ₁₆	49 ⁵ / ₈	17 ⁵ / ₁₆	147 ⁵ / ₈	26
1300 - 820	26 ³ / ₄	45 ¹ / ₄	21 ⁷ / ₁₆	90 ⁹ / ₁₆	60 ⁵ / ₈	70 ⁷ / ₈	57 ¹ / ₂	61 ⁷ / ₁₆	22 ¹ / ₁₆	153 ⁹ / ₁₆	33 ⁷ / ₁₆

Permissible tolerances:

- Tolerances in building construction to DIN 18202, Part 4, Group B
- Welded constructions: B/F to DIN EN ISO 13920
- Tolerances for conical seat (detail Y): ISO 2768-mH
- Discharge flanges to DIN EN 1092-1 PN6, DIN EN 1092-2 PN6

Loss diagram

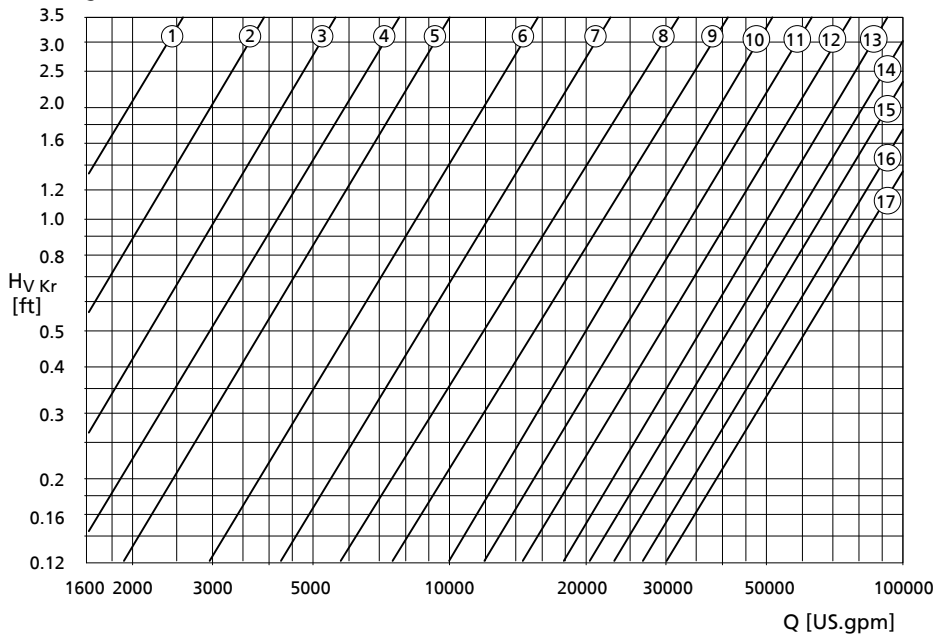

- ① - DN₂ = 7 ⁷/₈ inch
- ② - DN₂ = 9 ¹³/₁₆ inch
- ③ - DN₂ = 11 ¹³/₁₆ inch
- ④ - DN₂ = 13 ³/₄ inch
- ⑤ - DN₂ = 15 ³/₄ inch
- ⑥ - DN₂ = 19 ¹¹/₁₆ inch

- ⑦ - DN₂ = 23 ⁵/₈ inch
- ⑧ - DN₂ = 27 ⁹/₁₆ inch
- ⑨ - DN₂ = 31 ¹/₂ inch
- ⑩ - DN₂ = 35 ⁷/₁₆ inch
- ⑪ - DN₂ = 39 ³/₈ inch
- ⑫ - DN₂ = 43 ⁵/₁₆ inch

- ⑬ - DN₂ = 47 ¹/₄ inch
- ⑭ - DN₂ = 51 ³/₁₆ inch
- ⑮ - DN₂ = 55 ¹/₈ inch
- ⑯ - DN₂ = 59 ¹/₁₆ inch
- ⑰ - DN₂ = 63 inch

⁴²⁾ Always observe this dimension.

⁴³⁾ Value for maximum motor length

Calculation formulas:

$$H = H_{\text{geo}} + \Delta H_v$$

ΔH_v

- Loss in the elbow $h_{V_{Kr}}$ (see diagram)
- Loss in the riser (pipe friction)
- $H_{V_{\text{System}}}$ (valves, etc.)

$H_{V_{\text{System}}}$ must be determined for the specific system.

Diagram for minimum water level t_1

Covered chamber

t_1 [inch]

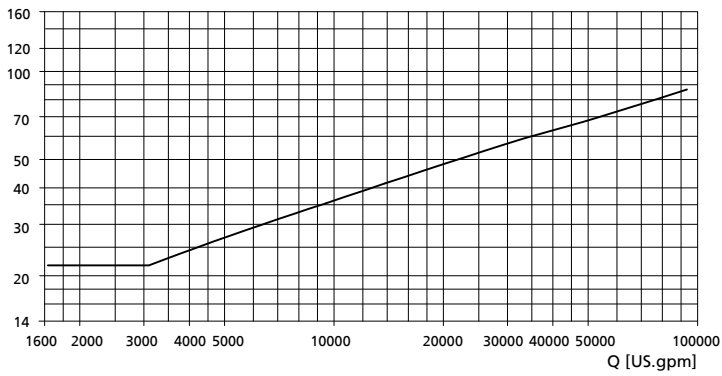

Minimum water level

Dimensions of the flow-straightening vane

Design of the inlet chamber wall surfaces (to prevent vortex formation)

The flow-straightening vane is indispensable for the inlet conditions of the pump. It prevents the development of a submerged vortex (floor vortex) which could cause a drop in performance, for example. In addition, the floor and wall surfaces of the intake chamber should be designed as a rough concrete surface. Rough surfaces minimize the separation of boundary layers that may cause wall and floor vortices.

Flow-straightening vane and inlet chamber

- The anti-swirl baffles in the bellmouth must be aligned with the flow-straightening vane.
- The bail of the pump is oriented in the same direction as the baffles in the bellmouth.

1	Bail	2	Anti-swirl baffles
3	Flow-straightening vane		

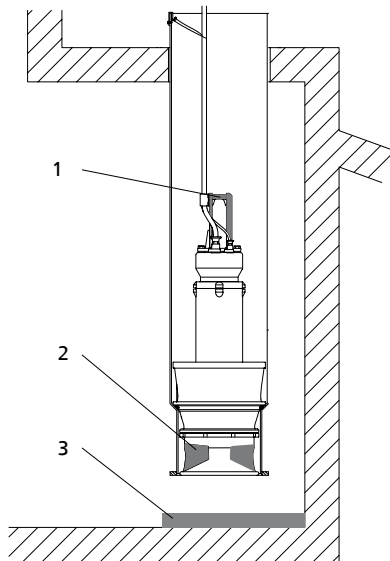

Installation position of the pump set

Variant 1 (concrete variant)
Flow-straightening vane cast from concrete

Variant 2
Steel section

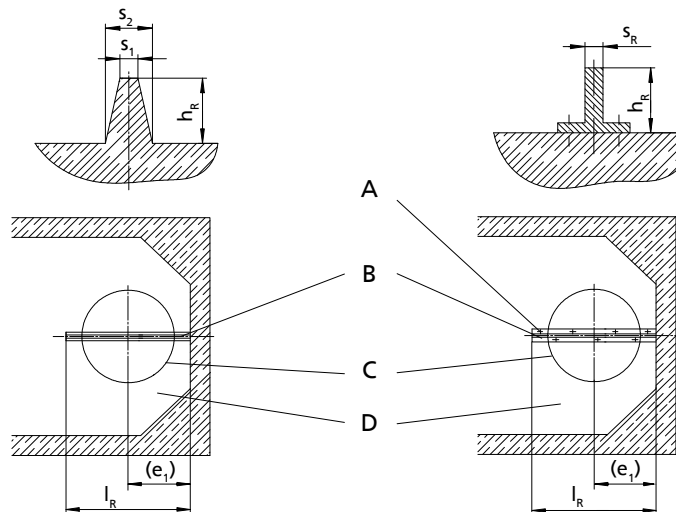

A	Bolted to the floor of the intake chamber	C	Discharge tube
B	Flow-straightening vane centered beneath the discharge tube	D	Intake chamber

Dimensions for installation types BU, CU, DU

Dimensions in [inch]

Size	h_R	s_R	s_1	s_2	$(e_1)^{44)}$		l_R	
					Design without suction umbrella d_s	Design with suction umbrella d_s	Design without suction umbrella d_s	Design with suction umbrella d_s
650 - 364	5 ⁷ / ₈	³ / ₈	¹³ / ₁₆	2 ³ / ₈	16 ⁹ / ₁₆	21 ¹ / ₄	32 ⁷ / ₈	37 ⁵ / ₈
650 - 365	5 ⁷ / ₈	³ / ₈	¹³ / ₁₆	2 ³ / ₈	16 ⁹ / ₁₆	21 ¹ / ₄	32 ⁷ / ₈	37 ⁵ / ₈
650 - 404	5 ⁷ / ₈	³ / ₈	¹³ / ₁₆	2 ³ / ₈	16 ⁹ / ₁₆	21 ¹ / ₄	32 ⁷ / ₈	37 ⁵ / ₈
650 - 405	7 ¹ / ₂	³ / ₈	¹³ / ₁₆	2 ³ / ₄	16 ⁹ / ₁₆	21 ¹ / ₄	34 ⁷ / ₁₆	41 ⁵ / ₁₆
800 - 505	7 ¹ / ₂	³ / ₈	¹³ / ₁₆	2 ³ / ₄	19 ¹¹ / ₁₆	24 ⁷ / ₁₆	41 ⁵ / ₁₆	45 ¹ / ₄
800 - 535	9 ¹ / ₁₆	³ / ₈	1	3 ⁹ / ₁₆	19 ¹¹ / ₁₆	29 ¹ / ₂	43 ⁵ / ₁₆	53 ¹ / ₈
850 - 550	9 ¹ / ₁₆	³ / ₈	1	3 ⁹ / ₁₆	20 ¹¹ / ₁₆	29 ¹ / ₂	43 ⁵ / ₁₆	53 ¹ / ₈
900 - 600	9 ¹ / ₁₆	³ / ₈	1	3 ⁹ / ₁₆	21 ⁵ / ₈	29 ¹ / ₂	47 ¹ / ₄	59 ¹ / ₁₆
900 - 615	10 ⁷ / ₁₆	¹ / ₂	1	3 ¹⁵ / ₁₆	21 ⁵ / ₈	29 ¹ / ₂	51 ³ / ₁₆	59 ¹ / ₁₆
900 - 620	7 ¹ / ₂	³ / ₈	¹³ / ₁₆	2 ³ / ₄	21 ⁵ / ₈	24 ⁷ / ₁₆	41 ⁵ / ₁₆	45 ¹ / ₄
1000 - 655	10 ⁷ / ₁₆	¹ / ₂	1	3 ¹⁵ / ₁₆	23 ⁵ / ₈	33 ⁷ / ₁₆	51 ³ / ₁₆	59 ¹ / ₁₆
1300 - 820	13 ³ / ₁₆	¹ / ₂	1 ³ / ₁₆	4 ³ / ₄	29 ¹ / ₂	39 ³ / ₈	64	73 ¹³ / ₁₆

Dimensions for installation types BG, CG, DG

Dimensions in [inch]

Size	h_R	s_R	s_1	s_2
650 - 364	5 ⁷ / ₈	³ / ₈	¹³ / ₁₆	2 ³ / ₈
650 - 365	5 ⁷ / ₈	³ / ₈	¹³ / ₁₆	2 ³ / ₈
650 - 404	5 ⁷ / ₈	³ / ₈	¹³ / ₁₆	2 ³ / ₈
650 - 405	7 ¹ / ₂	³ / ₈	¹³ / ₁₆	2 ³ / ₄
800 - 505	7 ¹ / ₂	³ / ₈	¹³ / ₁₆	2 ³ / ₄
800 - 535	9 ¹ / ₁₆	³ / ₈	1	3 ⁹ / ₁₆
850 - 550	9 ¹ / ₁₆	³ / ₈	1	3 ⁹ / ₁₆
900 - 600	9 ¹ / ₁₆	³ / ₈	1	3 ⁹ / ₁₆
900 - 615	10 ⁷ / ₁₆	¹ / ₂	1	3 ¹⁵ / ₁₆
900 - 620	7 ¹ / ₂	³ / ₈	¹³ / ₁₆	2 ³ / ₄
1000 - 655	10 ⁷ / ₁₆	¹ / ₂	1	3 ¹⁵ / ₁₆
1300 - 820	13 ³ / ₁₆	¹ / ₂	1 ³ / ₁₆	4 ³ / ₄

 Length l_R of the flow-straightening vane must be adjusted to the 45° angle of the inlet chamber.

44) See installation examples for types BU, CU and DU

General arrangement drawings [mm]

Example of installation type BU (Amacan S 650 - 364 to 800 - 505)

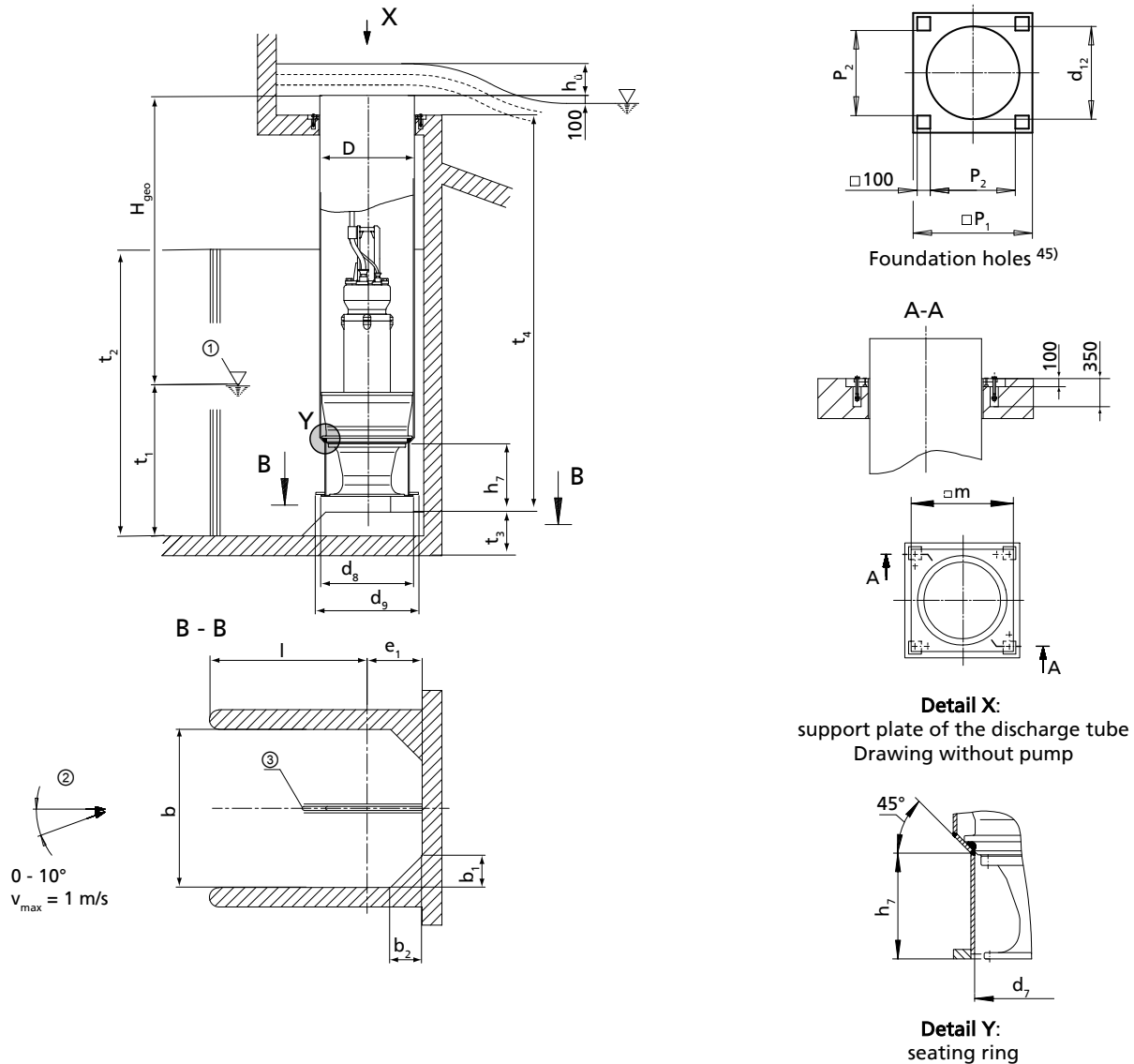

- ① Minimum water level (values see diagram on the next page)
- ② Approach flow
- ③ Flow-straightening vane (⇔ Page 80)

All dimensions in [mm]

Pump size	D	b	b ₁		b ₂		d ₇	d ₈	d ₉	d ₁₂
			without suction umbrella d ₈	with suction umbrella d ₉	without suction umbrella d ₈	with suction umbrella d ₉				
650 - 364	660	1000	200	–	200	–	530	660	900	700
650 - 365	660	1000	200	–	200	–	530	660	900	700
650 - 404	660	1000	200	–	200	–	530	660	900	700
650 - 405	660	1250	250	–	250	–	530	660	900	700
800 - 505	813	1250	250	–	250	–	680	810	1050	850

45) All dimensions for foundation holes apply to discharge tube design without intermediate flange.

All dimensions in [mm]

Pump size	e ₁ ⁴⁶⁾		h ₇	l _{min.}	m	p ₁	p ₂	t ₃ ⁴⁶⁾	t _{4 min.} ⁴⁷⁾
	without suction umbrella d ₈	with suction umbrella d ₉							
650 - 364	420	540	225	580	750	850	590	260	2350
650 - 365	420	540	225	580	750	850	590	260	2350
650 - 404	420	540	265	580	750	850	590	260	2560
650 - 405	420	540	265	830	750	850	590	320	2720
800 - 505	500	620	335	750	910	1000	740	320	2660

t₂ = 1.1 x water level; max. 2 x t₁ (depending on head H and structure)

Height of corner lining (b₁ and b₂) like t₂

Permissible tolerances:

- Tolerances in building construction to DIN 18202, Part 4, Group B
- Welded constructions: B/F to DIN EN ISO 13920
- Tolerances for conical seat (detail Y): ISO 2768-mH

Loss diagram

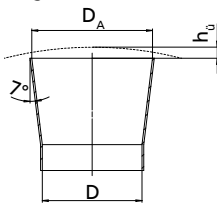

Overflow head h₀

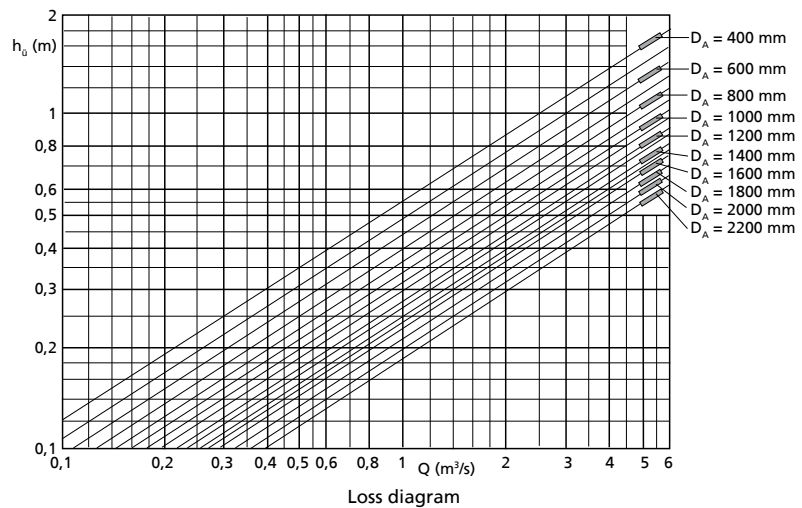

Loss diagram

Calculation formulas:

$$H = H_{\text{geo}} + \Delta H_v$$

$$\Delta H_v$$

- Overflow head h₀ (see diagram)
- Loss in the riser (pipe friction)
- Outlet loss v²/2g (v refers to D_a)

Overflow head h₀ depends on Q and the discharge diameter Ø D_a. The characteristic curve values only apply to unimpeded outlet in all directions; otherwise they are approximate values only.

⁴⁶⁾ Always observe this dimension.

⁴⁷⁾ Value for maximum motor length

Diagram for minimum water level t_1

Open chamber

t_1 (mm)

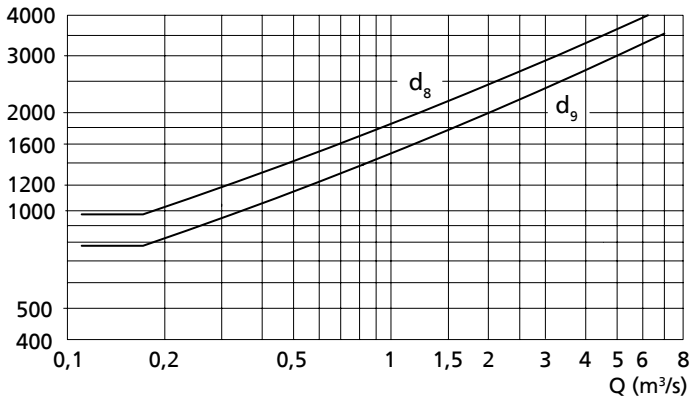

Minimum water level

d_8 = Design: **without** suction umbrella (standard)

d_9 = Design: **with** suction umbrella

Example of installation type BU (Amacan S 800 - 535 to 1300 - 820)

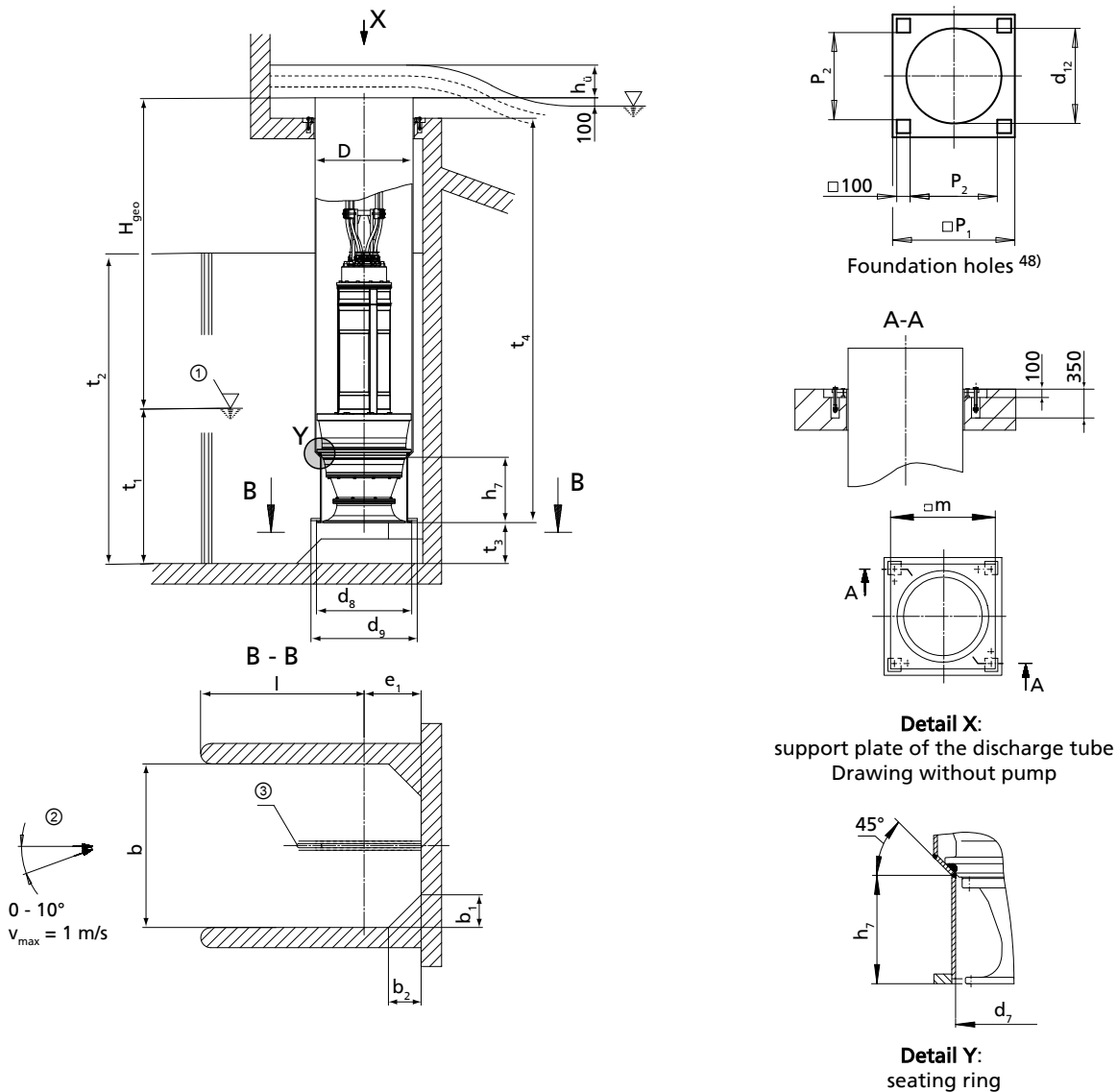

- ① Minimum water level (values see diagram on the next page)
- ② Approach flow
- ③ Flow-straightening vane (⇒ Page 80)

All dimensions in [mm]

Pump size	D	b	b ₁		b ₂		d ₇	d ₈	d ₉	d ₁₂
			without suction umbrella d ₈	with suction umbrella d ₉	without suction umbrella d ₈	with suction umbrella d ₉				
800 - 535	813	1500	300	-	300	-	720	810	1300	850
850 - 550	868	1500	300	-	300	-	740	865	1300	920
900 - 600	914	1500	300	-	300	-	800	910	1300	970
900 - 615	914	1800	360	-	360	-	780	910	1300	970
900 - 620	914	1250	250	-	250	-	770	910	1050	970
1000 - 655	1016	1800	360	-	360	-	920	1015	1500	1070
1300 - 820	1320	2300	460	-	460	-	1080	1320	1800	1380

48) All dimensions for foundation holes apply to discharge tube design without intermediate flange.

All dimensions in [mm]

Pump size	e ₁ ⁴⁹⁾		h ₇	l _{min.}	m	p ₁	p ₂	t ₃ ⁴⁹⁾	t _{4 min.} ⁵⁰⁾
	without suction umbrella d ₈	with suction umbrella d ₉							
800 - 535	500	750	325	1000	910	1000	740	380	2800
850 - 550	525	750	375	975	980	1050	790	380	3250
900 - 600	550	750	415	950	1050	1120	860	380	3200
900 - 615	550	750	420	1250	1050	1120	860	440	3200
900 - 620	550	620	365	700	1050	1120	860	320	3200
1000 - 655	600	850	515	1200	1150	1220	960	440	3750
1300 - 820	750	1000	545	1550	1460	1520	1260	560	3900

t₂ = 1.1 x water level; max. 2 x t₁ (depending on head H and structure)

Height of corner lining (b₁ and b₂) like t₂

Permissible tolerances:

- Tolerances in building construction to DIN 18202, Part 4, Group B
- Welded constructions: B/F to DIN EN ISO 13920
- Tolerances for conical seat (detail Y): ISO 2768-mH

Loss diagram

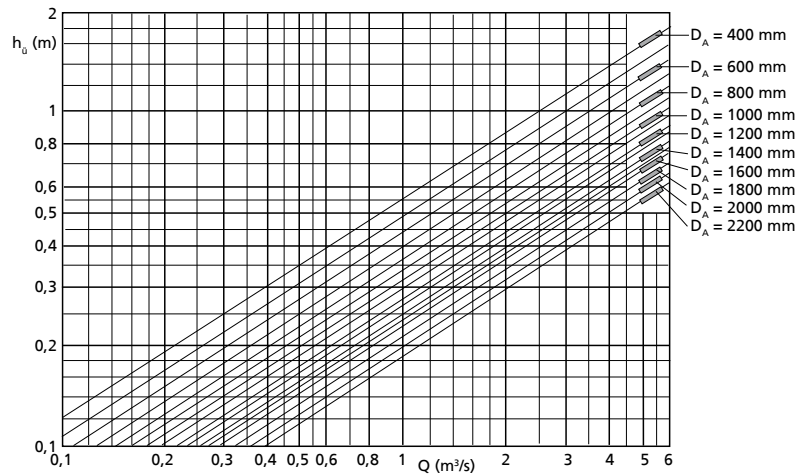
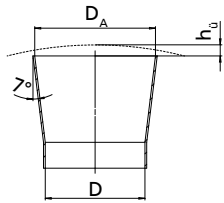

Overflow head h₀

Loss diagram

Calculation formulas:

$H = H_{geo} + \Delta H_v$

ΔH_v

- Overflow head h₀ (see diagram)
- Loss in the riser (pipe friction)
- Outlet loss $v^2/2g$ (v refers to D_a)

Overflow head h₀ depends on Q and the discharge diameter $\varnothing D_A$. The characteristic curve values only apply to unimpeded outlet in all directions; otherwise they are approximate values only.

⁴⁹⁾ Always observe this dimension.

⁵⁰⁾ Value for maximum motor length

Diagram for minimum water level t_1

Open chamber

t_1 (mm)

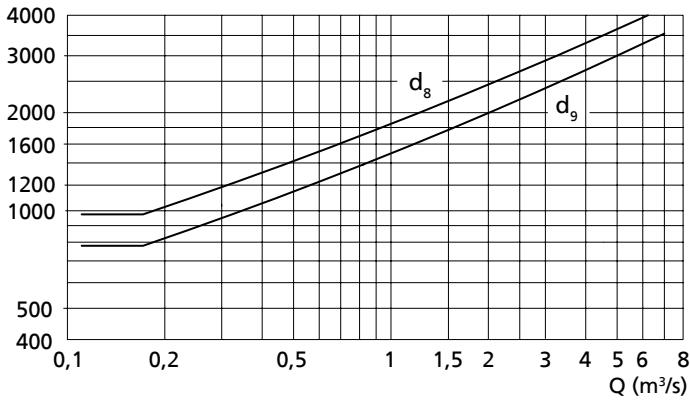

Minimum water level

d_8 = Design: **without** suction umbrella (standard)

d_9 = Design: **with** suction umbrella

Example of installation type BG (Amacan S 650 - 364 to 800 - 505)

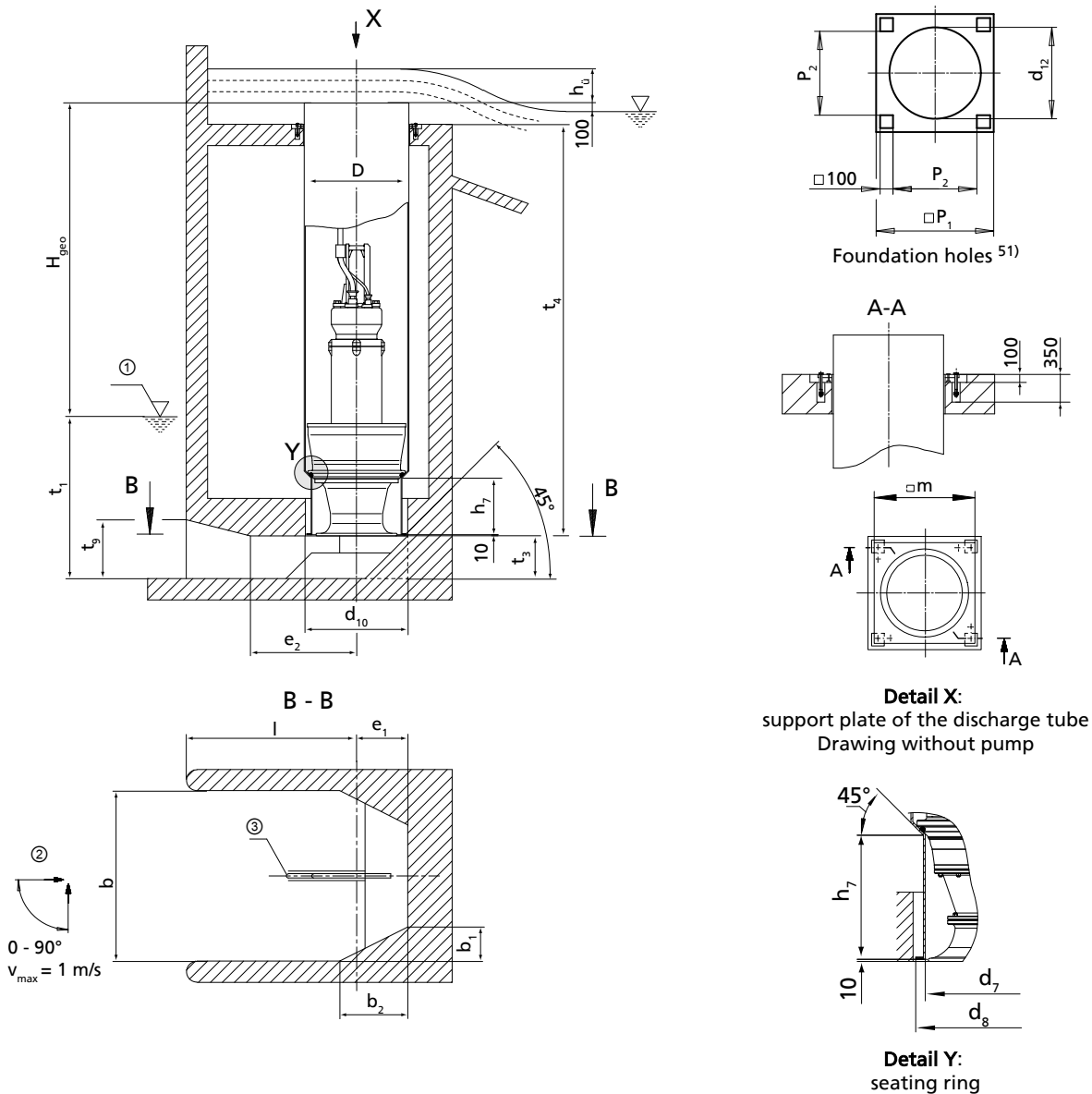

All dimensions in [mm]

Pump size	D	b	b ₁	b ₂	d ₇	d ₈	d ₁₀	d ₁₂	e ₁ ⁵²⁾
650 - 364	660	1000	200	400	530	550	600	700	300
650 - 365	660	1000	200	400	530	550	600	700	300
650 - 404	660	1000	200	400	530	550	600	700	300
650 - 405	660	1250	250	500	530	660	690	700	375
800 - 505	813	1250	250	500	680	700	735	850	375

51) All dimensions for foundation holes apply to discharge tube design without intermediate flange.
52) Always observe this dimension.

All dimensions in [mm]

Pump size	e ₂	h ₇	l _{min}	m	p ₁	p ₂	t ₃ ⁵³⁾	t _{4 min} ⁵⁴⁾	t ₉
650 - 364	500	225	1000	750	850	590	260	2350	375
650 - 365	500	225	1000	750	850	590	260	2350	375
650 - 404	500	265	1000	750	850	590	260	2560	375
650 - 405	625	265	1250	750	850	590	320	2720	470
800 - 505	625	335	1250	910	1000	740	320	2660	470

Permissible tolerances:

- Tolerances in building construction to DIN 18202, Part 4, Group B
- Welded constructions: B/F to DIN EN ISO 13920
- Tolerances for conical seat (detail Y): ISO 2768-mH

Loss diagram

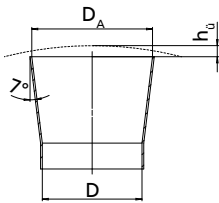

Overflow head h₀

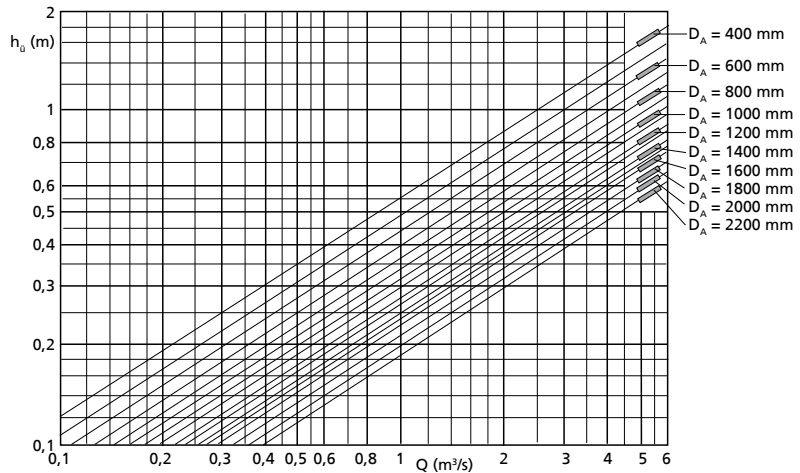

Loss diagram

Calculation formulas:

$$H = H_{geo} + \Delta H_v$$

$$\Delta H_v$$

- Overflow head h₀ (see diagram)
- Loss in the riser (pipe friction)
- Outlet loss v²/2g (v refers to D_a)

Overflow head h₀ depends on Q and the discharge diameter ∅ D_a. The characteristic curve values only apply to unimpeded outlet in all directions; otherwise they are approximate values only.

⁵³⁾ Always observe this dimension.

⁵⁴⁾ Value for maximum motor length

Diagram for minimum water level t_1

Covered chamber

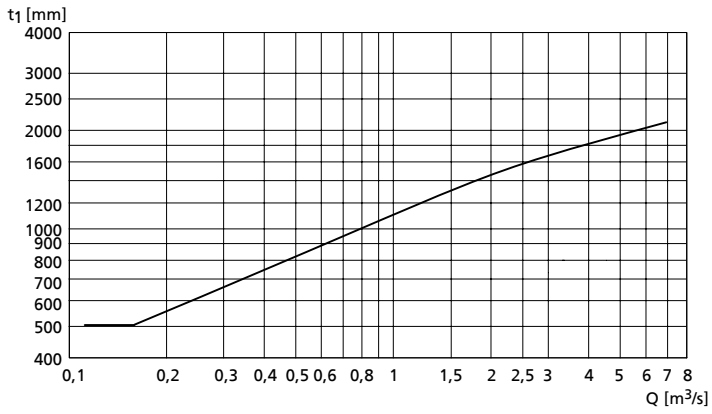

Minimum water level

Example of installation type BG (Amacan S 800 - 535 to 1300 - 820)

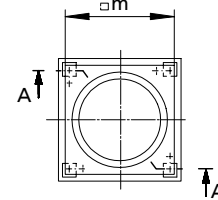
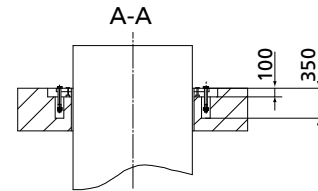
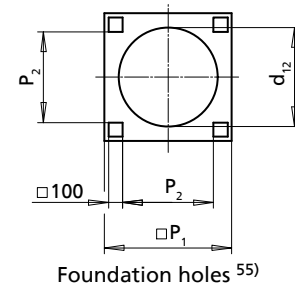
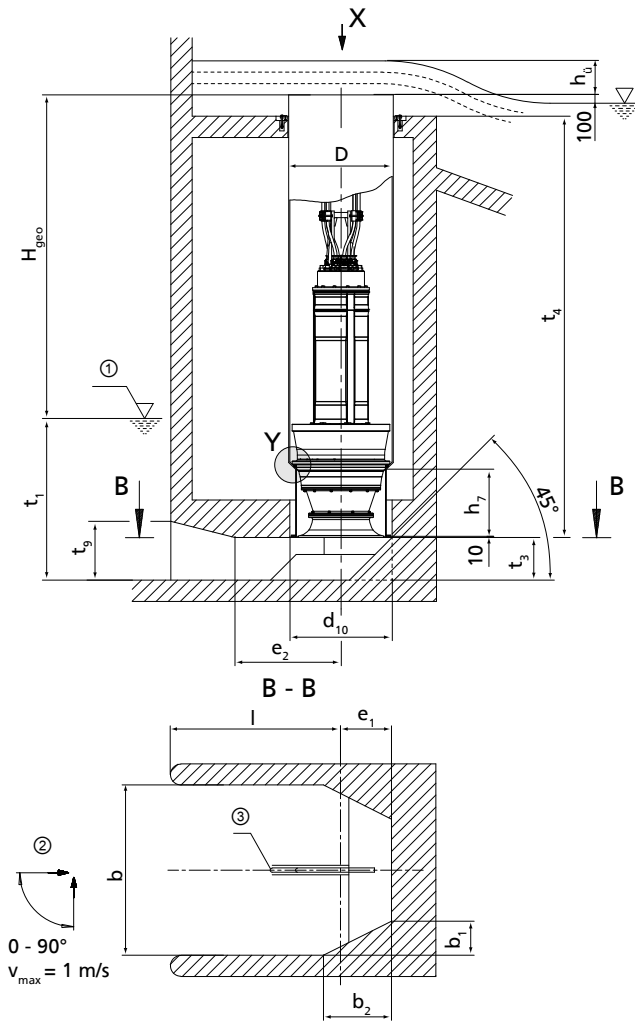

Detail X:
support plate of the discharge tube
Drawing without pump

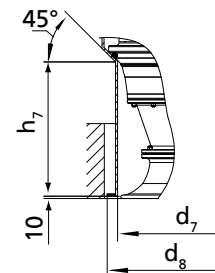

Detail Y:
seating ring

- ① Minimum water level (values see diagram on the next page)
- ② Approach flow
- ③ Flow-straightening vane (⇒ Page 80)

All dimensions in [mm]

Pump size	D	b	b ₁	b ₂	d ₇	d ₈	d ₁₀	d ₁₂	e ₁ ⁵⁶⁾
800 - 535	813	1500	300	600	720	840	885	850	450
850 - 550	868	1500	300	600	740	840	885	920	450
900 - 600	914	1500	300	600	800	820	860	970	450
900 - 615	914	1800	360	720	780	910	955	970	520
900 - 620	914	1250	250	500	770	790	830	970	415
1000 - 655	1016	1800	360	720	920	1000	1040	1070	520
1300 - 820	1320	2300	460	920	1080	1300	1360	1380	680

⁵⁵⁾ All dimensions for foundation holes apply to discharge tube design without intermediate flange.
⁵⁶⁾ Always observe this dimension.

All dimensions in [mm]

Pump size	e ₂	h ₇	l _{min}	m	p ₁	p ₂	t ₃ ⁵⁶⁾	t _{4 min} ⁵⁷⁾	t ₉
800 - 535	750	325	1500	910	1000	740	380	2800	570
850 - 550	750	375	1500	980	1050	790	380	3250	570
900 - 600	750	415	1500	1050	1120	860	380	3200	570
900 - 615	900	420	1800	1050	1120	860	440	3200	660
900 - 620	625	365	1250	1050	1120	860	320	3200	470
1000 - 655	900	515	1800	1150	1220	960	440	3750	660
1300 - 820	1150	545	2300	1460	1520	1260	560	3900	850

Permissible tolerances:

- Tolerances in building construction to DIN 18202, Part 4, Group B
- Welded constructions: B/F to DIN EN ISO 13920
- Tolerances for conical seat (detail Y): ISO 2768-mH

Loss diagram

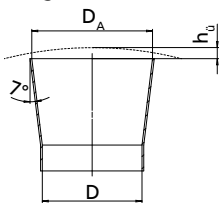

Overflow head h₀

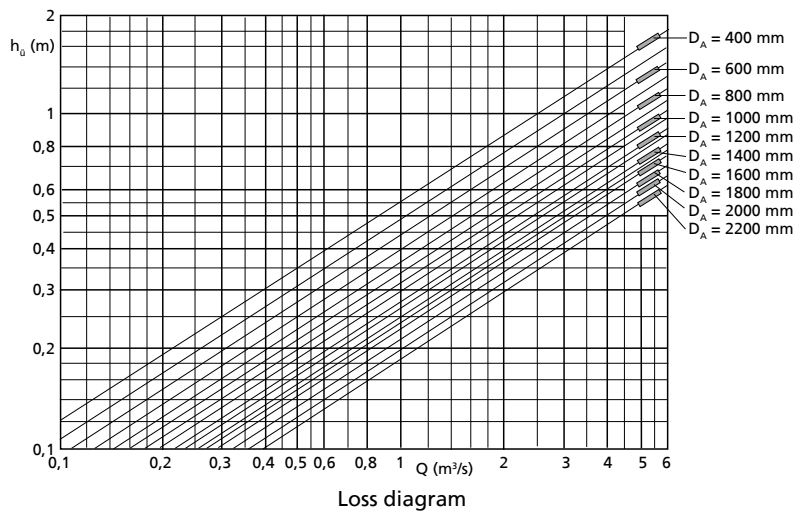

Calculation formulas:

$$H = H_{geo} + \Delta H_v$$

ΔH_v

- Overflow head h₀ (see diagram)
- Loss in the riser (pipe friction)
- Outlet loss $v^2/2g$ (v refers to D_a)

Overflow head h₀ depends on Q and the discharge diameter $\varnothing D_a$. The characteristic curve values only apply to unimpeded outlet in all directions; otherwise they are approximate values only.

⁵⁷⁾ Value for maximum motor length

Diagram for minimum water level t_1

Covered chamber

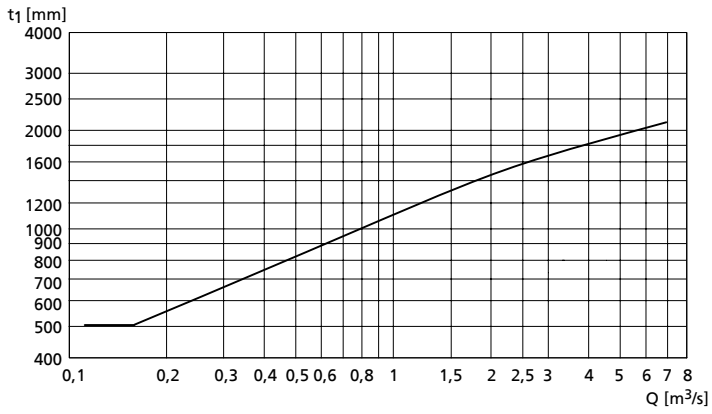

Minimum water level

Example of installation type CU (Amacan S 650 - 364 to 800 - 505)

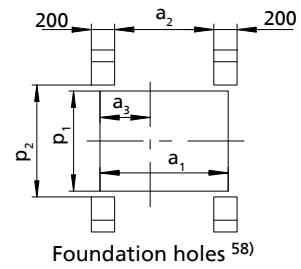
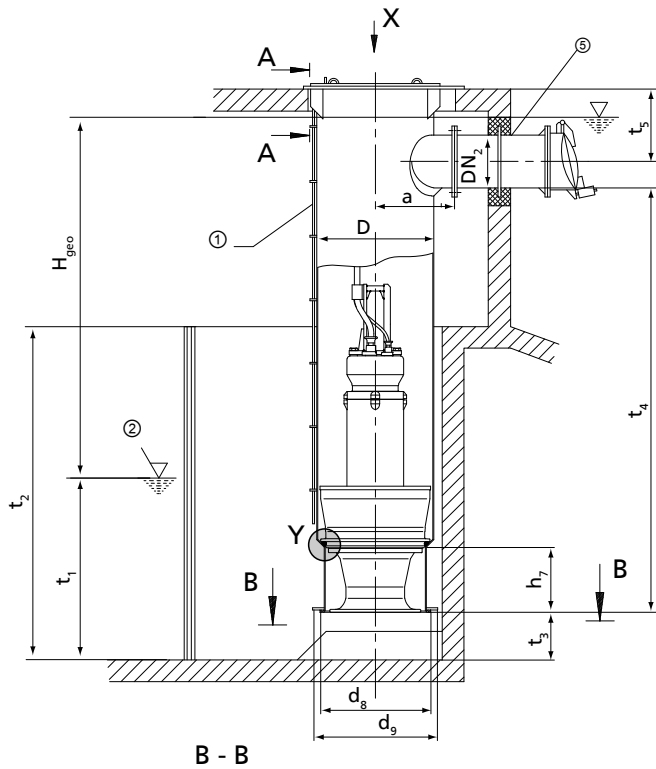

Foundation holes ⁵⁸⁾

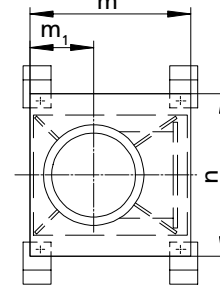
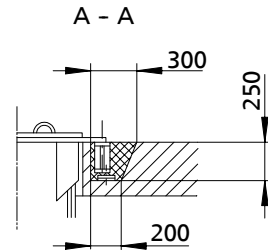

Detail X:
support plate of the discharge tube
Drawing without pump

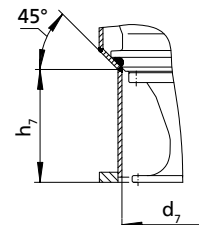
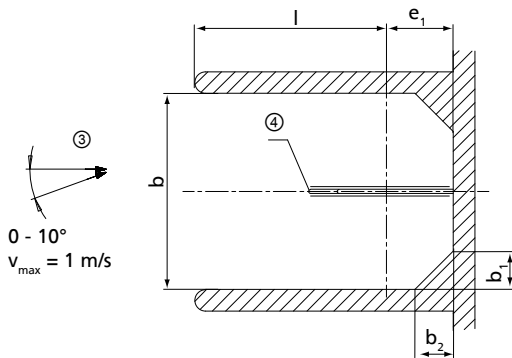

Detail Y:
seating ring

- ① Vent line
- ② Minimum water level (values see diagram on the next page)
- ③ Approach flow
- ④ Flow-straightening vane (⇒ Page 80)
- ⑤ Connect the discharge pipe to the discharge tube without transmitting any stresses and strains.

⁵⁸⁾ All dimensions for foundation holes apply to discharge tube design without intermediate flange.

All dimensions in [mm]

Pump size	D	DN ₂ min	DN ₂ max	a	a ₁ ⁵⁹⁾	a ₂ ⁵⁹⁾	a ₃ ⁵⁹⁾	b	b ₁		b ₂		d ₇
									without suction umbrella d ₈	with suction umbrella d ₉	without suction umbrella d ₈	with suction umbrella d ₉	
650 - 364	660	400	600	610	1050	800	405	1000	200	–	200	–	530
650 - 365	660	400	600	610	1050	800	405	1000	200	–	200	–	530
650 - 404	660	400	600	610	1050	800	405	1000	200	–	200	–	530
650 - 405	660	400	600	610	1050	800	405	1250	250	–	250	–	530
800 - 505	813	500	800	700	1220	970	480	1250	250	–	250	–	680

All dimensions in [mm]

Pump size	d ₈	d ₉	e ₁ ⁶⁰⁾		h ₇	l _{min}	m ⁶¹⁾	m ₁ ⁶¹⁾	n ⁶¹⁾	p ₁ ⁶¹⁾	p ₂ ⁶¹⁾	t ₃ ⁶⁰⁾	t _{4 min} ⁶²⁾	t ₅ ⁶¹⁾
			without suction umbrella d ₈	with suction umbrella d ₉										
650 - 364	660	900	420	540	225	580	1100	430	1160	860	960	260	2350	720
650 - 365	660	900	420	540	225	580	1100	430	1160	860	960	260	2350	720
650 - 404	660	900	420	540	265	580	1100	430	1160	860	960	260	2600	720
650 - 405	660	900	420	540	265	830	1100	430	1160	860	960	320	2750	720
800 - 505	810	1050	500	620	335	750	1270	505	1375	1075	1175	320	2700	835

t₂ = 1.1 x water level; max. 2 x t₁ (depending on head H and structure)

Height of corner lining (b₁ and b₂) like t₂

Permissible tolerances:

- Tolerances in building construction to DIN 18202, Part 4, Group B
- Welded constructions: B/F to DIN EN ISO 13920
- Tolerances for conical seat (detail Y): ISO 2768-mH
- Discharge flanges to DIN EN 1092-1 PN6, DIN EN 1092-2 PN6

⁵⁹⁾ Selected for DN2 max.

⁶⁰⁾ Always observe these dimensions.

⁶¹⁾ Selected for DN2 max.

⁶²⁾ Value for maximum motor length

Loss diagram

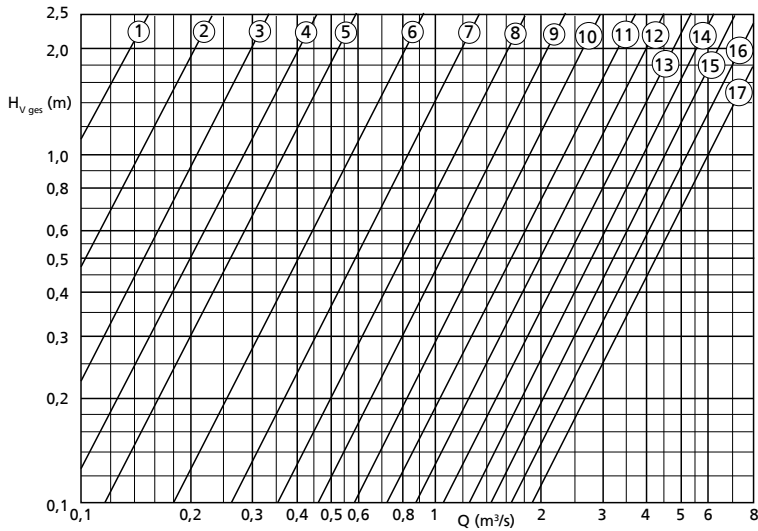

- | | | |
|------------------------------|-------------------------------|-------------------------------|
| ① - DN ₂ = 200 mm | ⑦ - DN ₂ = 600 mm | ⑬ - DN ₂ = 1200 mm |
| ② - DN ₂ = 250 mm | ⑧ - DN ₂ = 700 mm | ⑭ - DN ₂ = 1300 mm |
| ③ - DN ₂ = 300 mm | ⑨ - DN ₂ = 800 mm | ⑮ - DN ₂ = 1400 mm |
| ④ - DN ₂ = 350 mm | ⑩ - DN ₂ = 900 mm | ⑯ - DN ₂ = 1500 mm |
| ⑤ - DN ₂ = 400 mm | ⑪ - DN ₂ = 1000 mm | ⑰ - DN ₂ = 1600 mm |
| ⑥ - DN ₂ = 500 mm | ⑫ - DN ₂ = 1100 mm | |

Calculation formulas:

$$H = H_{\text{geo}} + \Delta H_v$$

ΔH_v

- Loss in the riser (pipe friction)
- $H_{v \text{ ges.}}$ (see diagram)

- $H_{v \text{ ges.}}$ comprises:

- Elbow
- Discharge pipe length = 5 x DN₂
- Swing check valve
- Outlet losses $v^2/2g$

Diagram for minimum water level t₁

Open chamber

t₁ (mm)

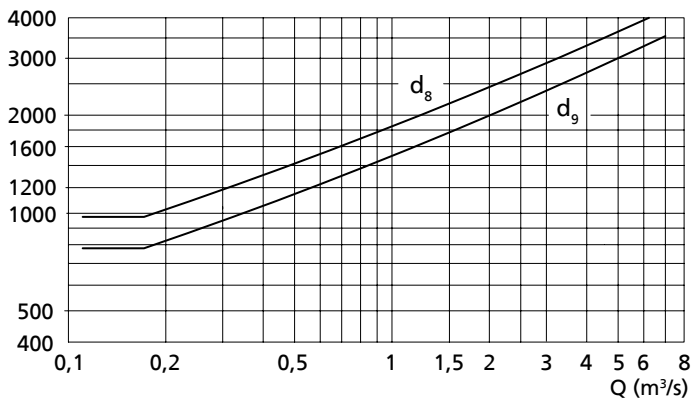

Minimum water level

d₈ = Design: **without** suction umbrella (standard)

d₉ = Design: **with** suction umbrella

Example of installation type CU (Amacan S 800 - 535 to 1300 - 820)

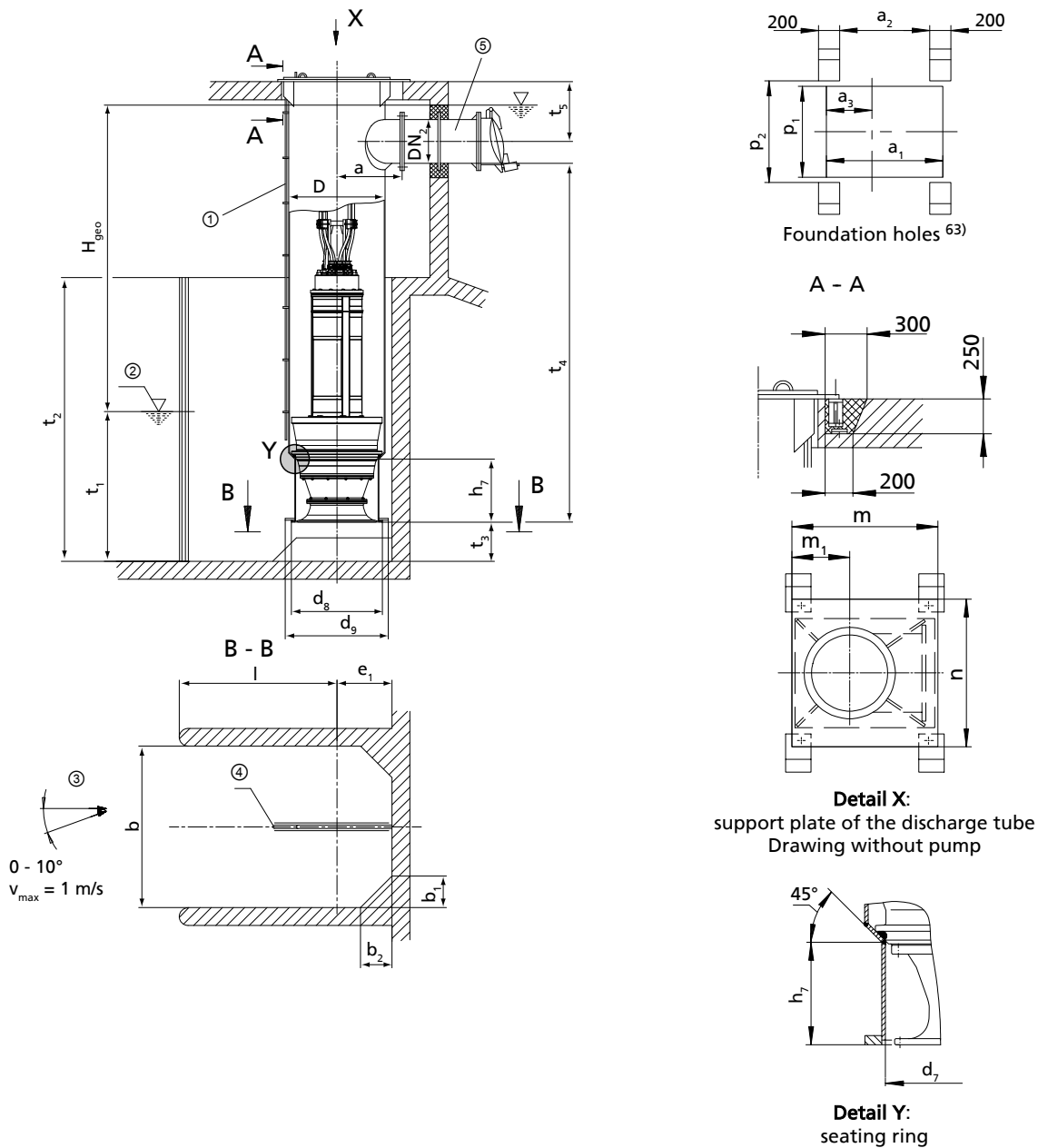

All dimensions in [mm]

Pump size	D	DN ₂ min	DN ₂ max	a	a ₁ ⁶⁶⁾	a ₂ ⁶⁶⁾	a ₃ ⁶⁶⁾	b	b ₁		b ₂		d ₇
									without suction umbrella d ₈	with suction umbrella d ₉	without suction umbrella d ₈	with suction umbrella d ₉	
800 - 535	813	500	800	700	1220	970	480	1500	300	-	300	-	720
850 - 550	868	500	800	730	1275	1020	505	1500	300	-	300	-	740
900 - 600	914	600	900	760	1320	1070	530	1500	300	-	300	-	800

⁶³⁾ All dimensions for foundation holes apply to discharge tube design without intermediate flange.

Pump size	D	DN ₂ min	DN ₂ max	a	a ₁ ⁶⁶⁾	a ₂ ⁶⁶⁾	a ₃ ⁶⁶⁾	b	b ₁		b ₂		d ₇
									without suction umbrella d ₈	with suction umbrella d ₉	without suction umbrella d ₈	with suction umbrella d ₉	
900 - 615	914	600	900	760	1320	1070	530	1800	360	-	360	-	780
900 - 620	914	600	900	760	1320	1070	530	1250	250	-	250	-	770
1000 - 655	1016	700	1000	810	1430	1160	580	1800	360	-	360	-	920
1300 - 820	1320	1000	1300	960	1720	1470	720	2300	460	-	460	-	1080

All dimensions in [mm]

Pump size	d ₈	d ₉	e ₁ ⁶⁴⁾		h ₇	l _{min}	m ⁶⁶⁾	m ₁ ⁶⁶⁾	n ⁶⁶⁾	p ₁ ⁶⁶⁾	p ₂ ⁶⁶⁾	t ₃ ⁶⁴⁾	t _{4 min} ⁶⁵⁾	t ₅ ⁶⁶⁾
			without suction umbrella d ₈	with suction umbrella d ₉										
800 - 535	810	1300	500	750	325	1000	1270	505	1375	1075	1175	380	2800	835
850 - 550	865	1300	525	750	375	975	1325	530	1375	1075	1175	380	3250	835
900 - 600	910	1300	550	750	415	950	1380	560	1480	1180	1280	380	3200	925
900 - 615	910	1300	550	750	420	1250	1380	560	1480	1180	1280	440	3200	925
900 - 620	910	1050	550	620	365	700	1380	560	1480	1180	1280	320	3200	925
1000 - 655	1015	1500	600	850	515	1200	1520	625	1620	1280	1380	440	3750	980
1300 - 820	1320	1800	750	1000	545	1550	1810	765	1960	1620	1720	560	3900	1180

t₂ = 1.1 x water level; max. 2 x t₁ (depending on head H and structure)

Height of corner lining (b₁ and b₂) like t₂

Permissible tolerances:

- Tolerances in building construction to DIN 18202, Part 4, Group B
- Welded constructions: B/F to DIN EN ISO 13920
- Tolerances for conical seat (detail Y): ISO 2768-mH
- Discharge flanges to DIN EN 1092-1 PN6, DIN EN 1092-2 PN6

⁶⁴⁾ Always observe these dimensions.

⁶⁵⁾ Value for maximum motor length

⁶⁶⁾ Selected for DN2 max.

Loss diagram

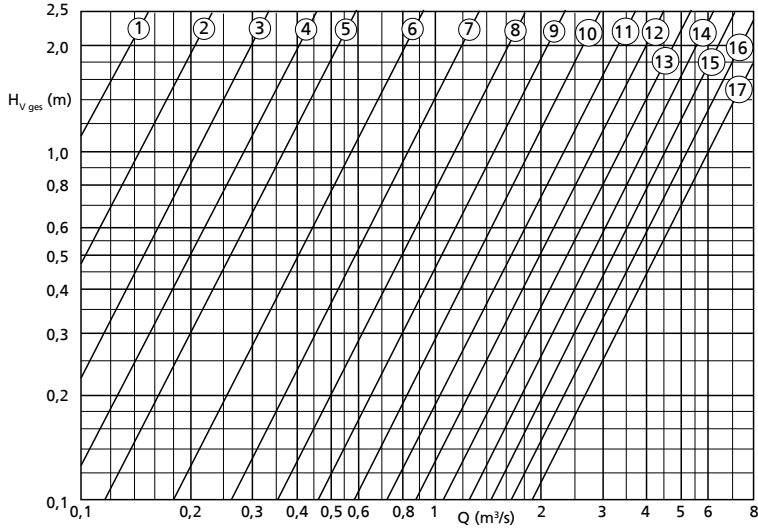

- | | | |
|------------------------------|-------------------------------|-------------------------------|
| ① - DN ₂ = 200 mm | ⑦ - DN ₂ = 600 mm | ⑬ - DN ₂ = 1200 mm |
| ② - DN ₂ = 250 mm | ⑧ - DN ₂ = 700 mm | ⑭ - DN ₂ = 1300 mm |
| ③ - DN ₂ = 300 mm | ⑨ - DN ₂ = 800 mm | ⑮ - DN ₂ = 1400 mm |
| ④ - DN ₂ = 350 mm | ⑩ - DN ₂ = 900 mm | ⑯ - DN ₂ = 1500 mm |
| ⑤ - DN ₂ = 400 mm | ⑪ - DN ₂ = 1000 mm | ⑰ - DN ₂ = 1600 mm |
| ⑥ - DN ₂ = 500 mm | ⑫ - DN ₂ = 1100 mm | |

Calculation formulas:

$$H = H_{geo} + \Delta H_v$$

ΔH_v - Loss in the riser (pipe friction)
- $H_{v ges}$. (see diagram)

- $H_{v ges}$ comprises:
- Elbow
- Discharge pipe length = 5 x DN₂
- Swing check valve
- Outlet losses $v^2/2g$

Diagram for minimum water level t₁

Open chamber

t₁ (mm)

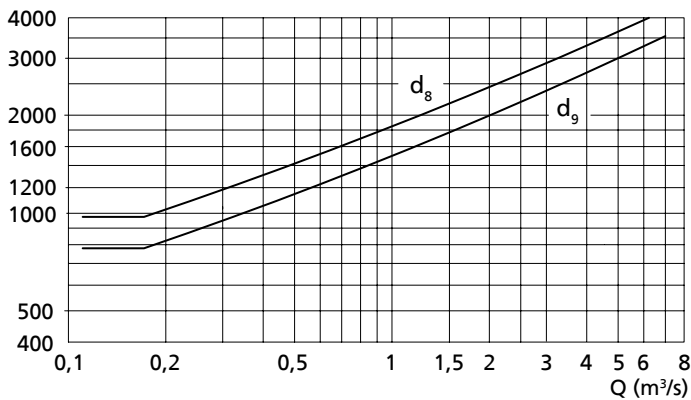

Minimum water level

d₈ = Design: **without** suction umbrella (standard)

d₉ = Design: **with** suction umbrella

Example of installation type CG (Amacan S 650 - 364 to 800 - 505)

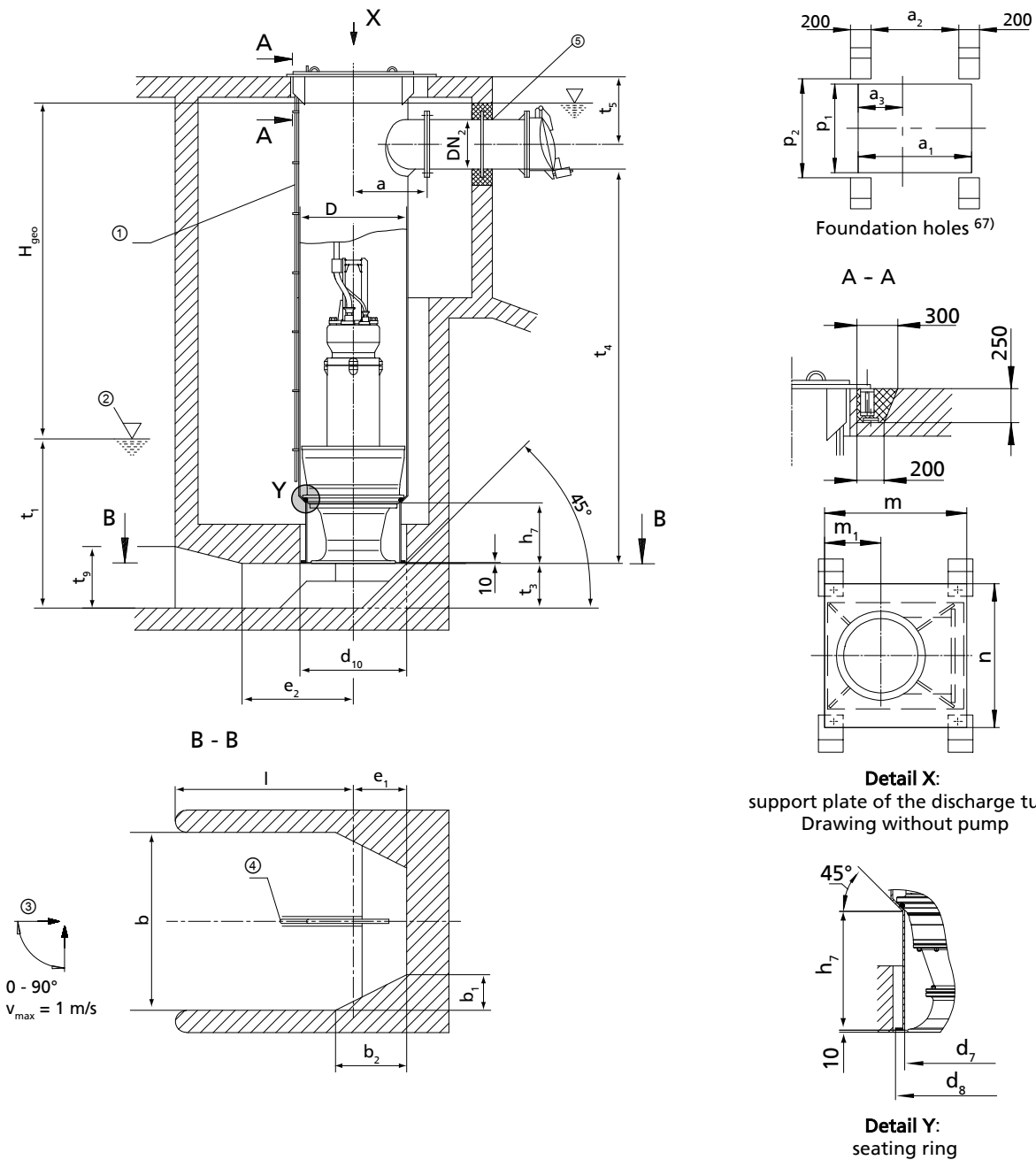

- ① Vent line
- ② Minimum water level (values see diagram on the next page)
- ③ Approach flow
- ④ Flow-straightening vane (⇒ Page 80)
- ⑤ Connect the discharge pipe to the discharge tube without transmitting any stresses and strains.

67) All dimensions for foundation holes apply to discharge tube design without intermediate flange.

All dimensions in [mm]

Pump size	D	DN ₂ min	DN ₂ max	a	a ₁ ⁶⁸⁾	a ₂ ⁶⁸⁾	a ₃ ⁶⁸⁾	b	b ₁	b ₂	d ₇	d ₈	d ₁₀
650 - 364	660	400	600	610	1050	800	405	1000	200	400	530	550	600
650 - 365	660	400	600	610	1050	800	405	1000	200	400	530	550	600
650 - 404	660	400	600	610	1050	800	405	1000	200	400	530	550	600
650 - 405	660	400	600	610	1050	800	405	1250	250	500	530	660	690
800 - 505	813	500	800	700	1220	970	480	1250	250	500	680	700	735

All dimensions in [mm]

Pump size	e ₁ ⁶⁹⁾	e ₂	h ₇	l _{min}	m ⁶⁸⁾	m ₁ ⁶⁸⁾	n ⁶⁸⁾	p ₁ ⁶⁸⁾	p ₂ ⁶⁸⁾	t ₃ ⁶⁹⁾	t _{4 min} ⁷⁰⁾	t _{5 min} ⁶⁸⁾	t ₉
650 - 364	300	500	225	1000	1100	430	1160	860	960	260	2350	720	375
650 - 365	300	500	225	1000	1100	430	1160	860	960	260	2350	720	375
650 - 404	300	500	265	1000	1100	430	1160	860	960	260	2600	720	375
650 - 405	375	625	265	1250	1100	430	1160	860	960	320	2750	720	470
800 - 505	375	625	335	1250	1270	505	1375	1075	1175	320	2700	835	470

Permissible tolerances:

- Tolerances in building construction to DIN 18202, Part 4, Group B
- Welded constructions: B/F to DIN EN ISO 13920
- Tolerances for conical seat (detail Y): ISO 2768-mH
- Discharge flanges to DIN EN 1092-1 PN6, DIN EN 1092-2 PN6

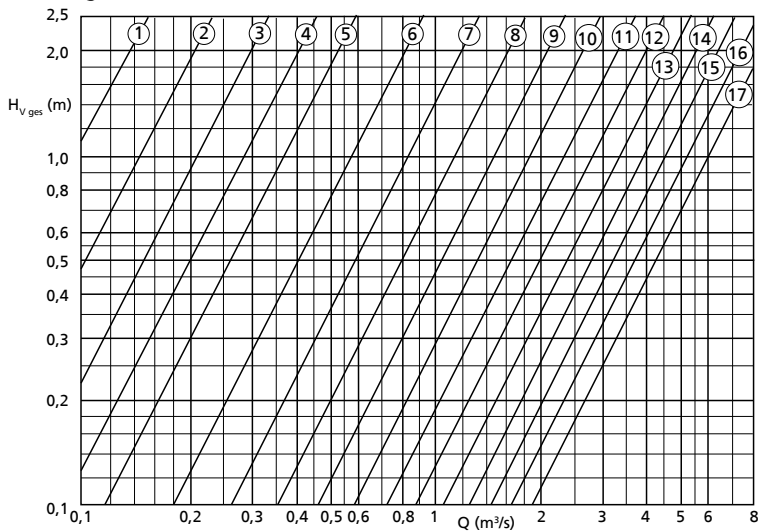
Loss diagram

- ① - DN₂ = 200 mm
- ② - DN₂ = 250 mm
- ③ - DN₂ = 300 mm
- ④ - DN₂ = 350 mm
- ⑤ - DN₂ = 400 mm
- ⑥ - DN₂ = 500 mm

- ⑦ - DN₂ = 600 mm
- ⑧ - DN₂ = 700 mm
- ⑨ - DN₂ = 800 mm
- ⑩ - DN₂ = 900 mm
- ⑪ - DN₂ = 1000 mm
- ⑫ - DN₂ = 1100 mm

- ⑬ - DN₂ = 1200 mm
- ⑭ - DN₂ = 1300 mm
- ⑮ - DN₂ = 1400 mm
- ⑯ - DN₂ = 1500 mm
- ⑰ - DN₂ = 1600 mm

Calculation formulas:

- 68) Selected for DN₂ max.
- 69) Always observe this dimension.
- 70) Value for maximum motor length

$$H = H_{\text{geo}} + \Delta H_v$$

ΔH_v

- Loss in the riser (pipe friction)
- $H_{v, \text{ges.}}$ (see diagram)

- $H_{v, \text{ges.}}$ comprises:

- Elbow
- Discharge pipe length = $5 \times DN_2$
- Swing check valve
- Outlet losses $v^2/2g$

Diagram for minimum water level t:

Covered chamber

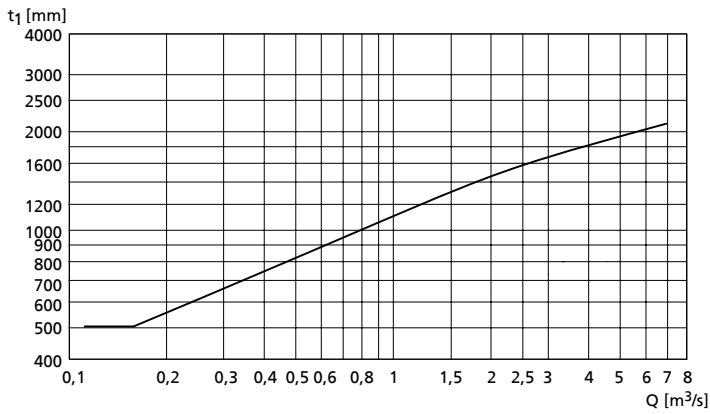

Minimum water level

Example of installation type CG (Amacan S 800 - 535 to 1300 - 820)

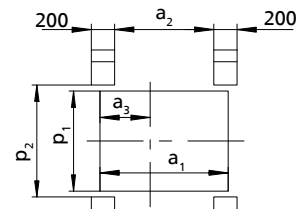
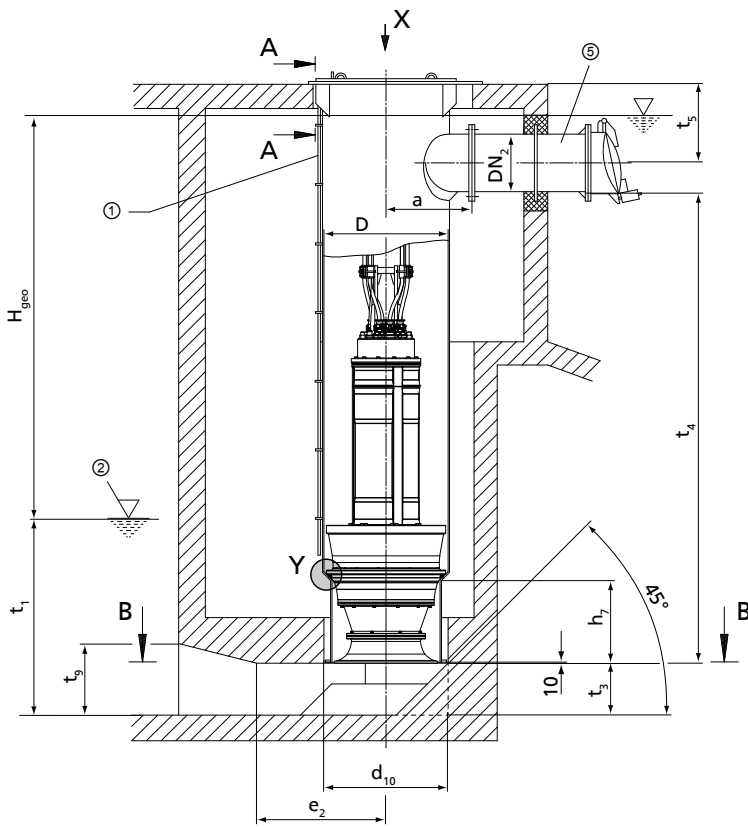

Foundation holes ⁷¹⁾

A - A

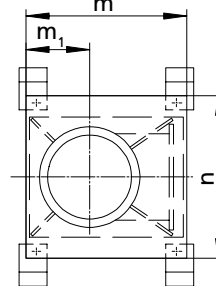
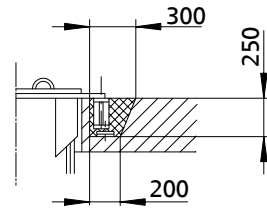

Detail X:
support plate of the discharge tube
Drawing without pump

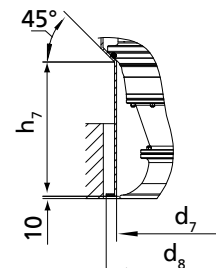

Detail Y:
seating ring

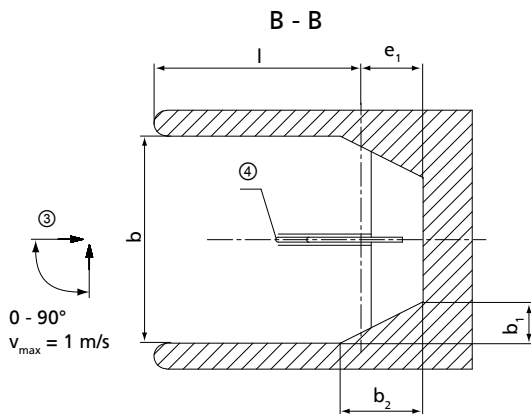

- ① Vent line
- ② Minimum water level (values see diagram on the next page)
- ③ Approach flow
- ④ Flow-straightening vane (⇒ Page 80)
- ⑤ Connect the discharge pipe to the discharge tube without transmitting any stresses and strains.

All dimensions in [mm]

Pump size	D	DN ₂ min	DN ₂ max	a	a ₁ ⁷²⁾	a ₂ ⁷²⁾	a ₃ ⁷²⁾	b	b ₁	b ₂	d ₇	d ₈	d ₁₀
800 - 535	813	500	800	700	1220	970	480	1500	300	600	720	840	885
850 - 550	868	500	800	730	1275	1020	505	1500	300	600	740	840	885
900 - 600	914	600	900	760	1320	1070	530	1500	300	600	800	820	860

Pump size	D	DN ₂ min	DN ₂ max	a	a ₁ ⁷²⁾	a ₂ ⁷²⁾	a ₃ ⁷²⁾	b	b ₁	b ₂	d ₇	d ₈	d ₁₀
900 - 615	914	600	900	760	1320	1070	530	1800	360	720	780	910	955
900 - 620	914	600	900	760	1320	1070	530	1250	250	500	770	790	830
1000 - 655	1016	700	1000	810	1430	1160	580	1800	360	720	920	1000	1040
1300 - 820	1320	1000	1300	960	1720	1470	720	2300	460	920	1080	1300	1360

All dimensions in [mm]

Pump size	e ₁ ⁷³⁾	e ₂	h ₇	l _{min}	m ⁷²⁾	m ₁ ⁷²⁾	n ⁷²⁾	p ₁ ⁷²⁾	p ₂ ⁷²⁾	t ₃ ⁷³⁾	t ₄ min ⁷⁴⁾	t ₅ min ⁷²⁾	t ₉
800 - 535	450	750	325	1500	1270	505	1375	1075	1175	380	2800	835	570
850 - 550	450	750	375	1500	1325	530	1375	1075	1175	380	3250	835	570
900 - 600	450	750	415	1500	1380	560	1480	1180	1280	380	3200	925	570
900 - 615	520	900	420	1800	1380	560	1480	1180	1280	440	3200	925	660
900 - 620	415	625	365	1250	1380	560	1480	1180	1280	320	3200	925	470
1000 - 655	520	900	515	1800	1520	625	1620	1280	1380	440	3750	980	660
1300 - 820	680	1150	545	2300	1810	765	1960	1620	1720	560	3900	1180	850

Permissible tolerances:

- Tolerances in building construction to DIN 18202, Part 4, Group B
- Welded constructions: B/F to DIN EN ISO 13920
- Tolerances for conical seat (detail Y): ISO 2768-mH
- Discharge flanges to DIN EN 1092-1 PN6, DIN EN 1092-2 PN6

Loss diagram

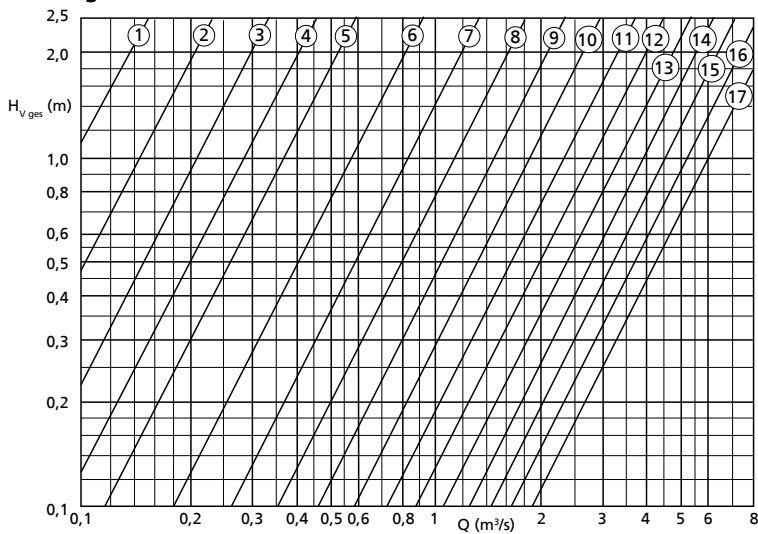

- ① - DN₂ = 200 mm
- ② - DN₂ = 250 mm
- ③ - DN₂ = 300 mm
- ④ - DN₂ = 350 mm
- ⑤ - DN₂ = 400 mm
- ⑥ - DN₂ = 500 mm

- ⑦ - DN₂ = 600 mm
- ⑧ - DN₂ = 700 mm
- ⑨ - DN₂ = 800 mm
- ⑩ - DN₂ = 900 mm
- ⑪ - DN₂ = 1000 mm
- ⑫ - DN₂ = 1100 mm

- ⑬ - DN₂ = 1200 mm
- ⑭ - DN₂ = 1300 mm
- ⑮ - DN₂ = 1400 mm
- ⑯ - DN₂ = 1500 mm
- ⑰ - DN₂ = 1600 mm

72) Selected for DN₂ max.

71) All dimensions for foundation holes apply to discharge tube design without intermediate flange.

72) Selected for DN₂ max.

73) Always observe this dimension.

74) Value for maximum motor length

Calculation formulas:

$$H = H_{\text{geo}} + \Delta H_v$$

ΔH_v

- Loss in the riser (pipe friction)
- $H_{v, \text{ges.}}$ (see diagram)

- $H_{v, \text{ges.}}$ comprises:

- Elbow
- Discharge pipe length = 5 x DN₂
- Swing check valve
- Outlet losses $v^2/2g$

Diagram for minimum water level t₁

Covered chamber

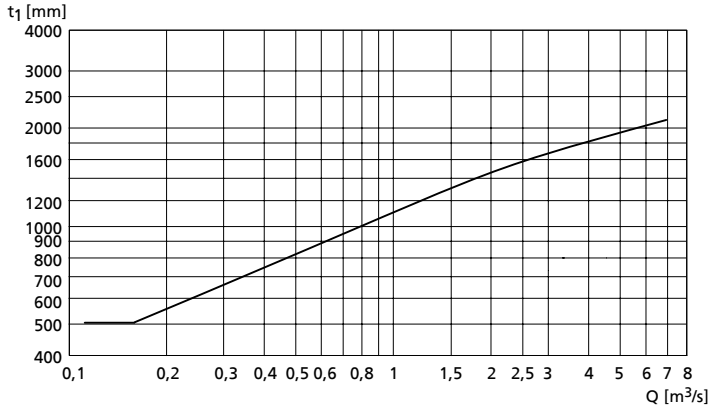

Minimum water level

Example of installation type DU (Amacan S 650 - 364 to 800 - 505)

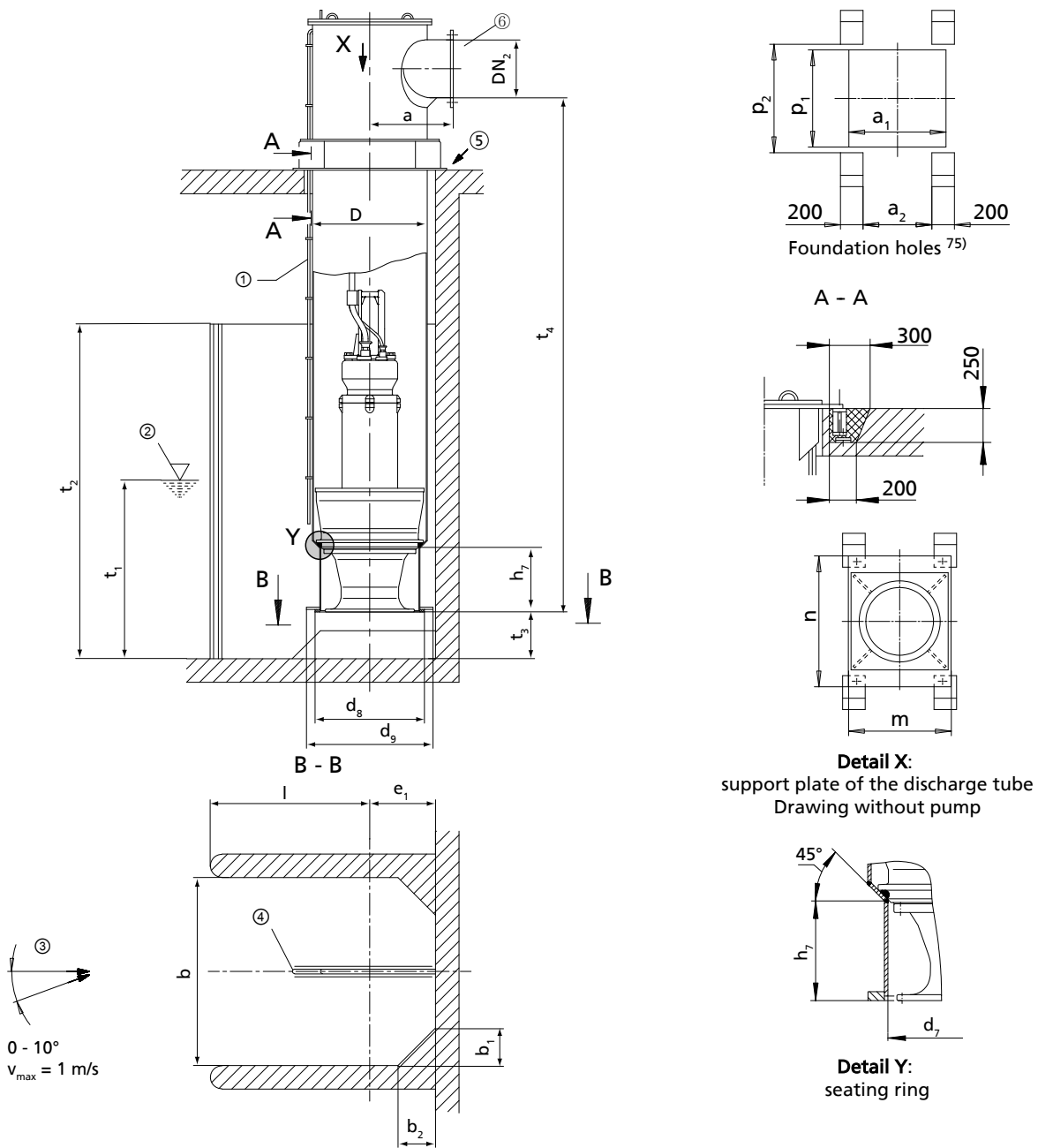

- ① Vent line
- ② Minimum water level (values see diagram on the next page)
- ③ Approach flow
- ④ Flow-straightening vane (⇒ Page 80)
- ⑤ Not pressure-proof
- ⑥ Connect the discharge pipe to the discharge tube without transmitting any stresses and strains.

75) All dimensions for foundation holes apply to discharge tube design without intermediate flange.

All dimensions in [mm]

Pump size	D	DN ₂ min	DN ₂ max	a	a ₁	a ₂	b	b ₁		b ₂		d ₇
								without suction umbrella d ₈	with suction umbrella d ₉	without suction umbrella d ₈	with suction umbrella d ₉	
650 - 364	660	400	600	610	810	560	1000	200	–	200	–	530
650 - 365	660	400	600	610	810	560	1000	200	–	200	–	530
650 - 404	660	400	600	610	810	560	1000	200	–	200	–	530
650 - 405	660	400	600	610	810	560	1250	250	–	250	–	530
800 - 505	813	500	800	700	960	710	1250	250	–	250	–	680

All dimensions in [mm]

Pump size	d ₈	d ₉	e ₁ ⁷⁶⁾		h ₇	l _{min}	m	n	p ₁	p ₂	t ₃ ⁷⁶⁾	t _{4 min} ⁷⁷⁾
			without suction umbrella d ₈	with suction umbrella d ₉								
650 - 364	660	900	420	540	225	580	860	1110	810	910	260	2350
650 - 365	660	900	420	540	225	580	860	1110	810	910	260	2350
650 - 404	660	900	420	540	265	580	860	1110	810	910	260	2600
650 - 405	660	900	420	540	265	830	860	1110	810	910	320	2750
800 - 505	810	1050	500	620	335	750	1030	1260	960	1060	320	2700

 $t_2 = 1.1 \times \text{water level}$; max. $2 \times t_1$ (depending on head H and structure)

 Height of corner lining (b₁ and b₂) like t₂

Permissible tolerances:

- Tolerances in building construction to DIN 18202, Part 4, Group B
- Welded constructions: B/F to DIN EN ISO 13920
- Tolerances for conical seat (detail Y): ISO 2768-mH
- Discharge flanges to DIN EN 1092-1 PN6, DIN EN 1092-2 PN6

⁷⁶⁾ Always observe this dimension.

⁷⁷⁾ Value for maximum motor length

Loss diagram

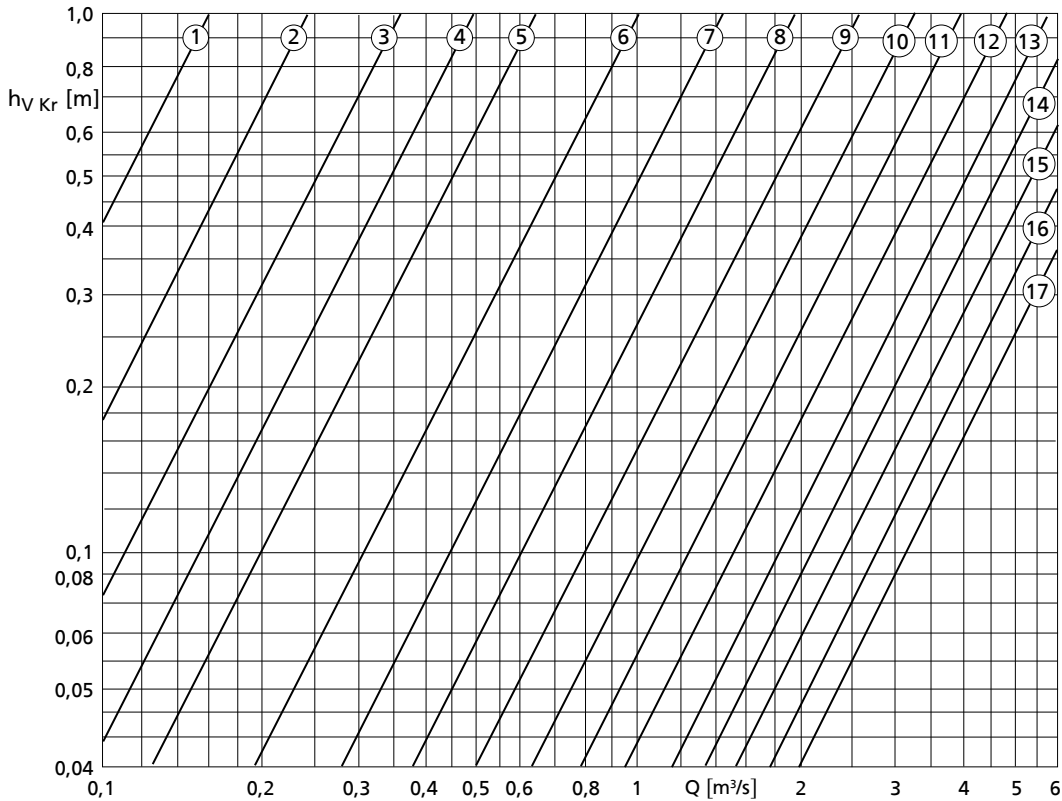

- | | | |
|------------------------------|-------------------------------|-------------------------------|
| ① - DN ₂ = 200 mm | ⑦ - DN ₂ = 600 mm | ⑬ - DN ₂ = 1200 mm |
| ② - DN ₂ = 250 mm | ⑧ - DN ₂ = 700 mm | ⑭ - DN ₂ = 1300 mm |
| ③ - DN ₂ = 300 mm | ⑨ - DN ₂ = 800 mm | ⑮ - DN ₂ = 1400 mm |
| ④ - DN ₂ = 350 mm | ⑩ - DN ₂ = 900 mm | ⑯ - DN ₂ = 1500 mm |
| ⑤ - DN ₂ = 400 mm | ⑪ - DN ₂ = 1000 mm | ⑰ - DN ₂ = 1600 mm |
| ⑥ - DN ₂ = 500 mm | ⑫ - DN ₂ = 1100 mm | |

Calculation formulas:

$$H = H_{\text{geo}} + \Delta H_v$$

$$\Delta H_v$$

- Loss in the elbow $h_{V, Kr}$ (see diagram)
- Loss in the riser (pipe friction)
- $H_{V, \text{System}}$ (valves, etc.)

$H_{V, \text{System}}$ must be determined for the specific system.

Diagram for minimum water level t_1

Open chamber

t_1 (mm)

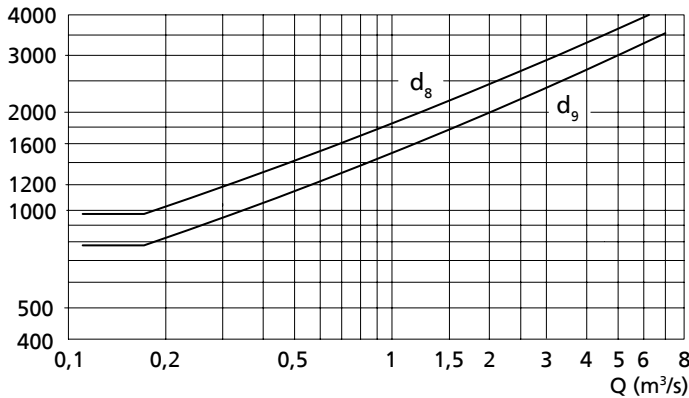

Minimum water level

d_8 = Design: **without** suction umbrella (standard)

d_9 = Design: **with** suction umbrella

Example of installation type DU (Amacan S 800 - 535 to 1300 - 820)

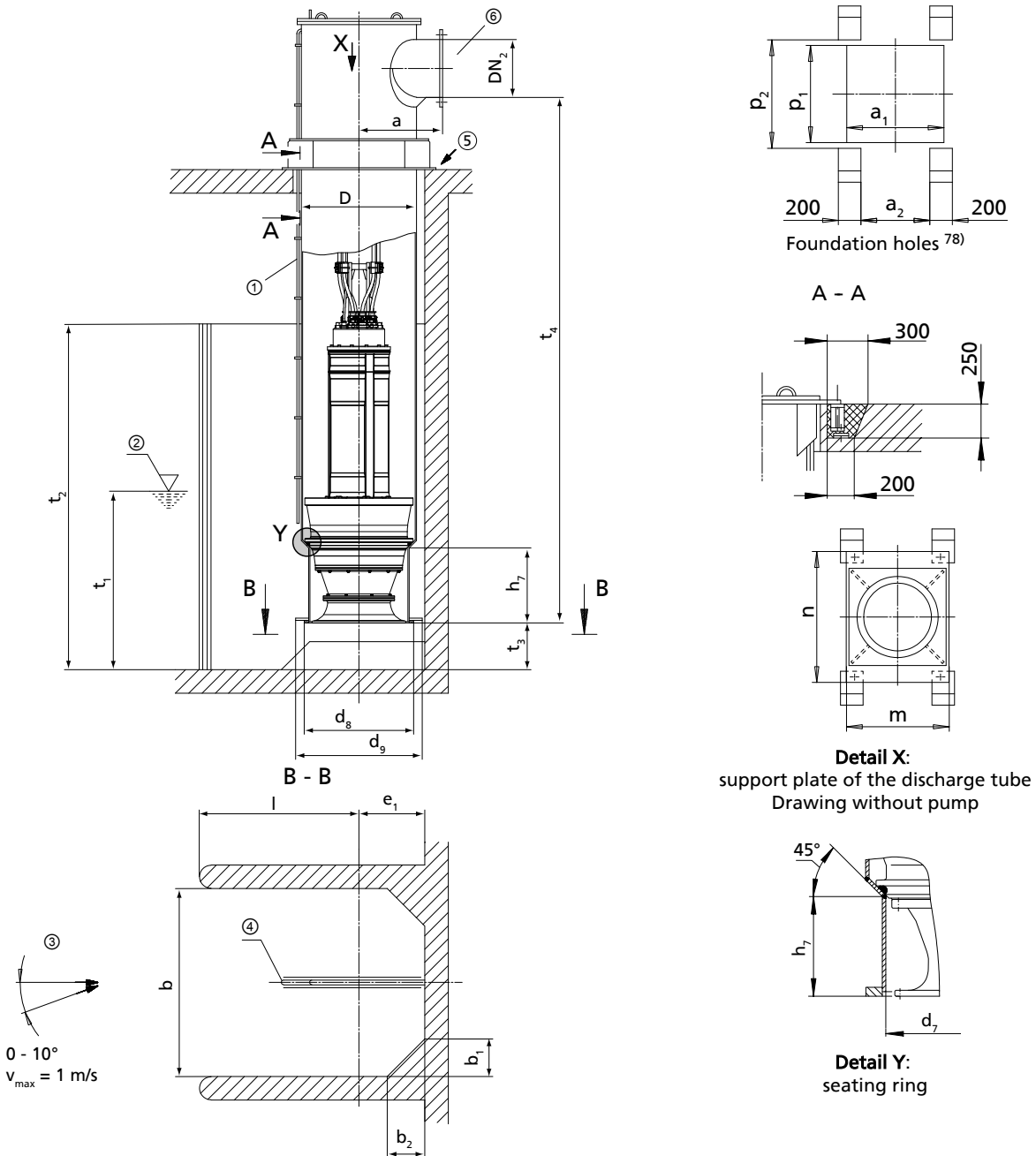

- ① Vent line
- ② Minimum water level (values see diagram on the next page)
- ③ Approach flow
- ④ Flow-straightening vane (⇒ Page 80)
- ⑤ Not pressure-proof
- ⑥ Connect the discharge pipe to the discharge tube without transmitting any stresses and strains.

78) All dimensions for foundation holes apply to discharge tube design without intermediate flange.

All dimensions in [mm]

Pump size	D	DN ₂ min	DN ₂ max	a	a ₁	a ₂	b	b ₁		b ₂		d ₇
								without suction umbrella d ₈	with suction umbrella d ₉	without suction umbrella d ₈	with suction umbrella d ₉	
800 - 535	813	500	800	700	960	710	1500	300	-	300	-	720
850 - 550	868	500	800	730	1010	760	1500	300	-	300	-	740
900 - 600	914	600	900	760	1060	810	1500	300	-	300	-	800
900 - 615	914	600	900	760	1060	810	1800	360	-	360	-	780
900 - 620	914	600	900	760	1060	810	1250	250	-	250	-	770
1000 - 655	1016	700	1000	810	1160	910	1800	360	-	360	-	920
1300 - 820	1320	1000	1300	960	1460	1210	2300	460	-	460	-	1080

All dimensions in [mm]

Pump size	d ₈	d ₉	e ₁ ⁷⁹⁾		h ₇	l _{min}	m	n	p ₁	p ₂	t ₃ ⁷⁹⁾	t ₄ min ⁸⁰⁾
			without suction umbrella d ₈	with suction umbrella d ₉								
800 - 535	810	1300	500	750	325	1000	1030	1260	960	1060	380	2800
850 - 550	865	1300	525	750	375	975	1080	1310	1010	1110	380	3250
900 - 600	910	1300	550	750	415	950	1130	1360	1060	1160	380	3200
900 - 615	910	1300	550	750	420	1250	1130	1360	1060	1160	440	3200
900 - 620	910	1050	550	620	365	700	1130	1360	1060	1160	320	3200
1000 - 655	1015	1500	600	850	515	1200	1240	1500	1160	1260	440	3750
1300 - 820	1320	1800	750	1000	545	1550	1540	1800	1460	1560	560	3900

t₂ = 1.1 x water level; max. 2 x t₁ (depending on head H and structure)

Height of corner lining (b₁ and b₂) like t₂

Permissible tolerances:

- Tolerances in building construction to DIN 18202, Part 4, Group B
- Welded constructions: B/F to DIN EN ISO 13920
- Tolerances for conical seat (detail Y): ISO 2768-mH
- Discharge flanges to DIN EN 1092-1 PN6, DIN EN 1092-2 PN6

⁷⁹⁾ Always observe this dimension.

⁸⁰⁾ Value for maximum motor length

Loss diagram

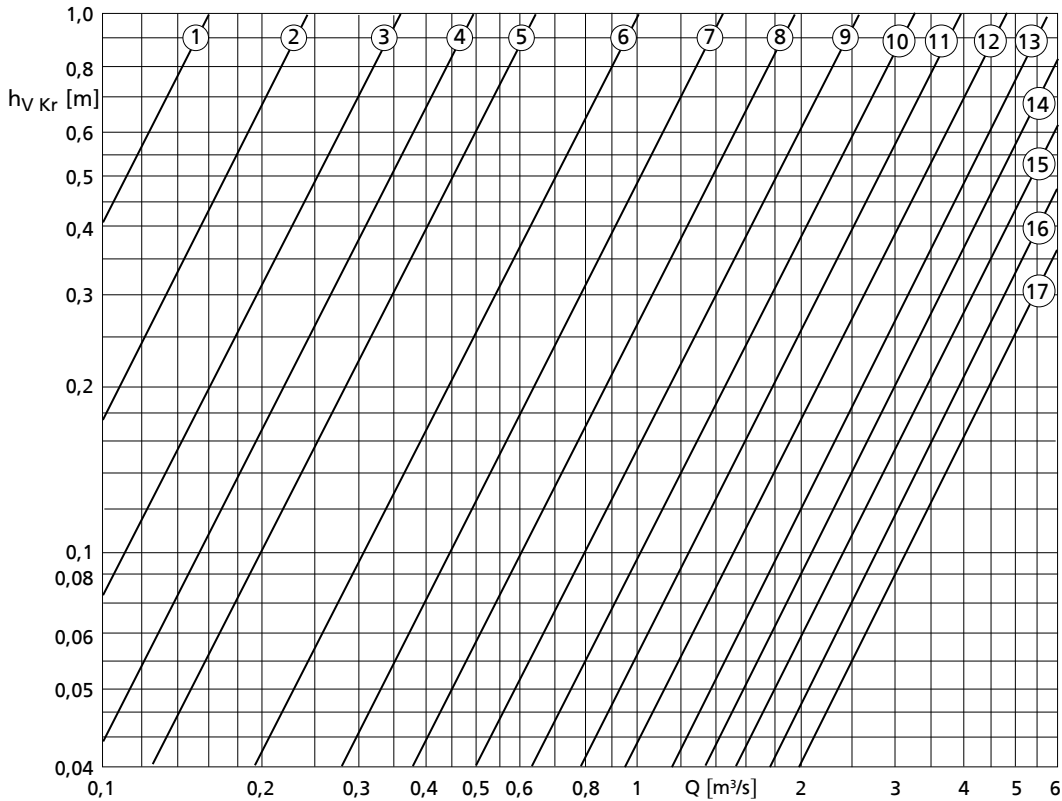

- | | | |
|------------------------------|-------------------------------|-------------------------------|
| ① - DN ₂ = 200 mm | ⑦ - DN ₂ = 600 mm | ⑬ - DN ₂ = 1200 mm |
| ② - DN ₂ = 250 mm | ⑧ - DN ₂ = 700 mm | ⑭ - DN ₂ = 1300 mm |
| ③ - DN ₂ = 300 mm | ⑨ - DN ₂ = 800 mm | ⑮ - DN ₂ = 1400 mm |
| ④ - DN ₂ = 350 mm | ⑩ - DN ₂ = 900 mm | ⑯ - DN ₂ = 1500 mm |
| ⑤ - DN ₂ = 400 mm | ⑪ - DN ₂ = 1000 mm | ⑰ - DN ₂ = 1600 mm |
| ⑥ - DN ₂ = 500 mm | ⑫ - DN ₂ = 1100 mm | |

Calculation formulas:

$$H = H_{\text{geo}} + \Delta H_V$$

$$\Delta H_V$$

- Loss in the elbow $h_{V, Kr}$ (see diagram)
- Loss in the riser (pipe friction)
- $H_{V, \text{System}}$ (valves, etc.)

$H_{V, \text{System}}$ must be determined for the specific system.

Diagram for minimum water level t_1

Open chamber

t_1 (mm)

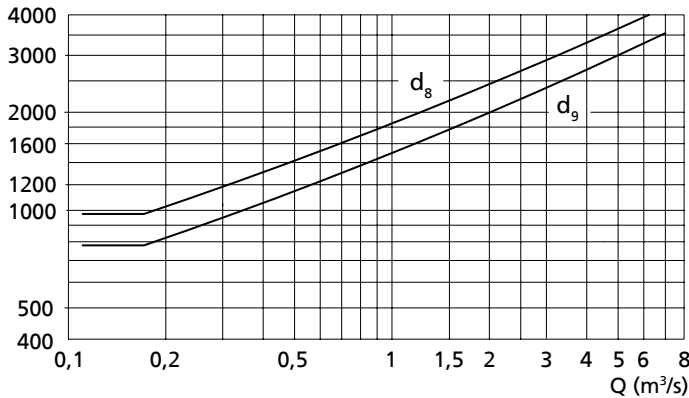

Minimum water level

d_8 = Design: **without** suction umbrella (standard)

d_9 = Design: **with** suction umbrella

Example of installation type DG (Amacan S 650 - 364 to 800 - 505)

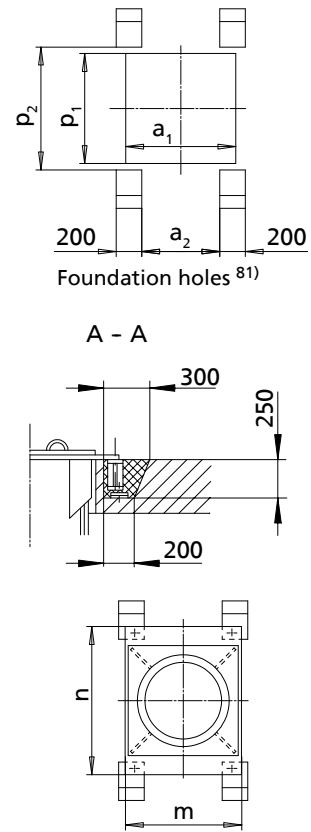
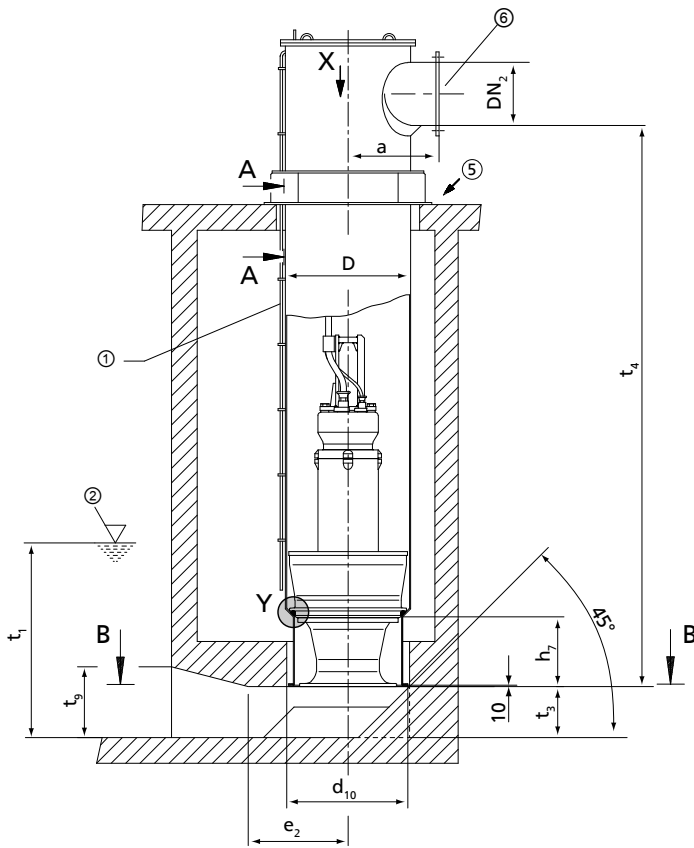

Detail X:
support plate of the discharge tube
Drawing without pump

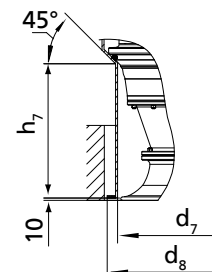
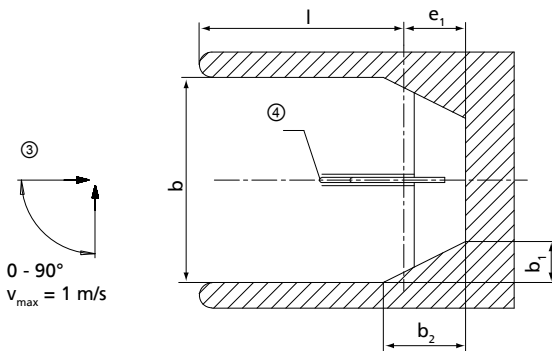

Detail Y:
seating ring

- ① Vent line
- ② Minimum water level (values see diagram on the next page)
- ③ Approach flow
- ④ Flow-straightening vane (⇒ Page 80)
- ⑤ Not pressure-proof
- ⑥ Connect the discharge pipe to the discharge tube without transmitting any stresses and strains.

81) All dimensions for foundation holes apply to discharge tube design without intermediate flange.

All dimensions in [mm]

Pump size	D	DN ₂ min	DN ₂ max	a	a ₁	a ₂	b	b ₁	b ₂	d ₇	d ₈	d ₁₀
650 - 364	660	400	600	610	810	560	1000	200	400	530	550	600
650 - 365	660	400	600	610	810	560	1000	200	400	530	550	600
650 - 404	660	400	600	610	810	560	1000	200	400	530	550	600
650 - 405	660	400	600	610	810	560	1250	250	500	530	660	690
800 - 505	813	500	800	700	960	710	1250	250	500	680	700	735

All dimensions in [mm]

Pump size	e ₁ ⁸²⁾	e ₂	h ₇	l _{min}	m	n	p ₁	p ₂	t ₃ ⁸²⁾	t _{4 min} ⁸³⁾	t ₉
650 - 364	300	500	225	1000	860	1110	810	910	260	2350	375
650 - 365	300	500	225	1000	860	1110	810	910	260	2350	375
650 - 404	300	500	265	1000	860	1110	810	910	260	2600	375
650 - 405	375	625	265	1250	860	1110	810	910	320	2750	470
800 - 505	375	625	335	1250	1030	1260	960	1060	320	2700	470

Permissible tolerances:

- Tolerances in building construction to DIN 18202, Part 4, Group B
- Welded constructions: B/F to DIN EN ISO 13920
- Tolerances for conical seat (detail Y): ISO 2768-mH
- Discharge flanges to DIN EN 1092-1 PN6, DIN EN 1092-2 PN6

82) Always observe this dimension.

83) Value for maximum motor length

Loss diagram

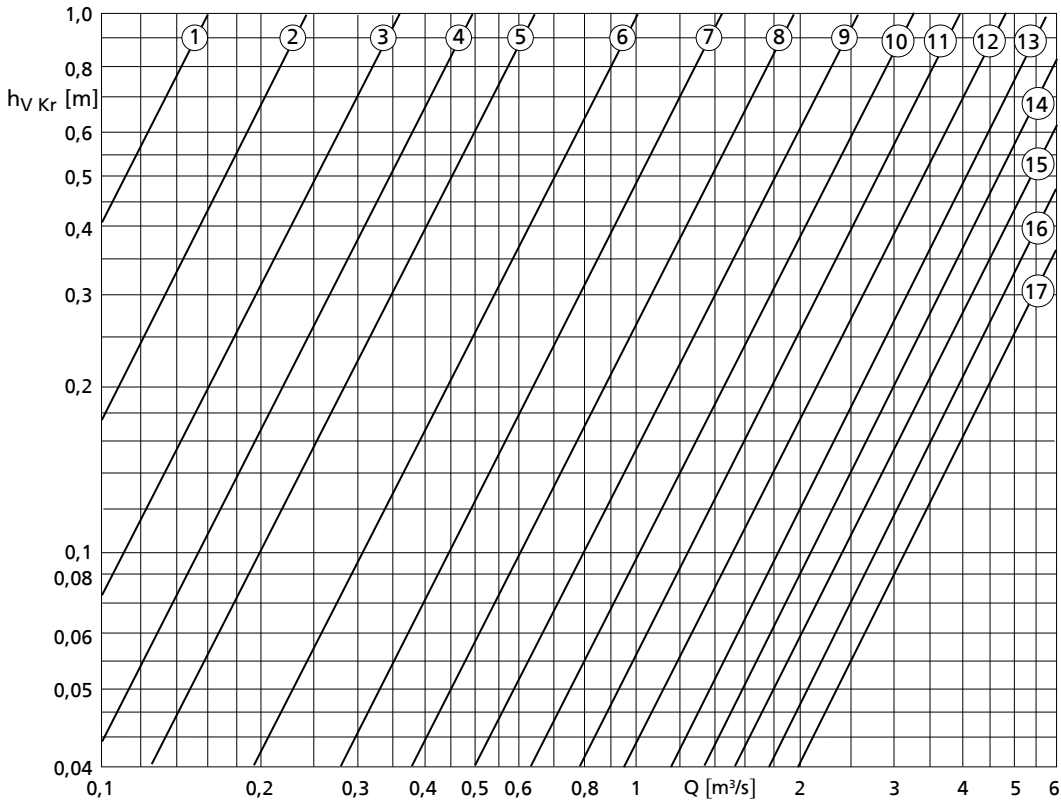

- | | | |
|------------------------------|-------------------------------|-------------------------------|
| ① - DN ₂ = 200 mm | ⑦ - DN ₂ = 600 mm | ⑬ - DN ₂ = 1200 mm |
| ② - DN ₂ = 250 mm | ⑧ - DN ₂ = 700 mm | ⑭ - DN ₂ = 1300 mm |
| ③ - DN ₂ = 300 mm | ⑨ - DN ₂ = 800 mm | ⑮ - DN ₂ = 1400 mm |
| ④ - DN ₂ = 350 mm | ⑩ - DN ₂ = 900 mm | ⑯ - DN ₂ = 1500 mm |
| ⑤ - DN ₂ = 400 mm | ⑪ - DN ₂ = 1000 mm | ⑰ - DN ₂ = 1600 mm |
| ⑥ - DN ₂ = 500 mm | ⑫ - DN ₂ = 1100 mm | |

Calculation formulas:

$$H = H_{\text{geo}} + \Delta H_v$$

$$\Delta H_v$$

- Loss in the elbow $h_{V, Kr}$ (see diagram)
- Loss in the riser (pipe friction)
- $H_{V, \text{System}}$ (valves, etc.)

$H_{V, \text{System}}$ must be determined for the specific system.

Diagram for minimum water level t_1

Covered chamber

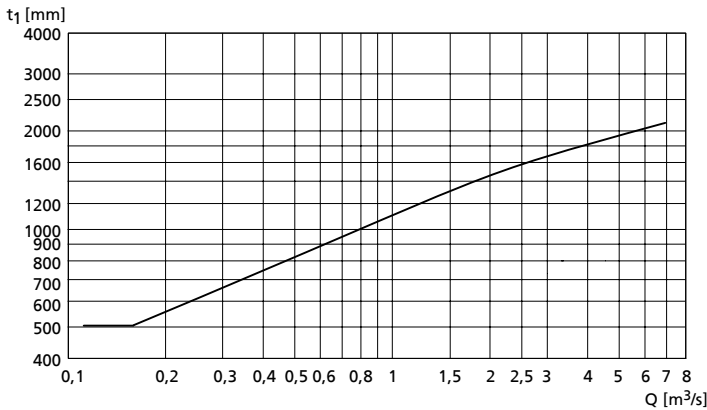

Minimum water level

Example of installation type DG (Amacan S 800 - 535 to 1300 - 820)

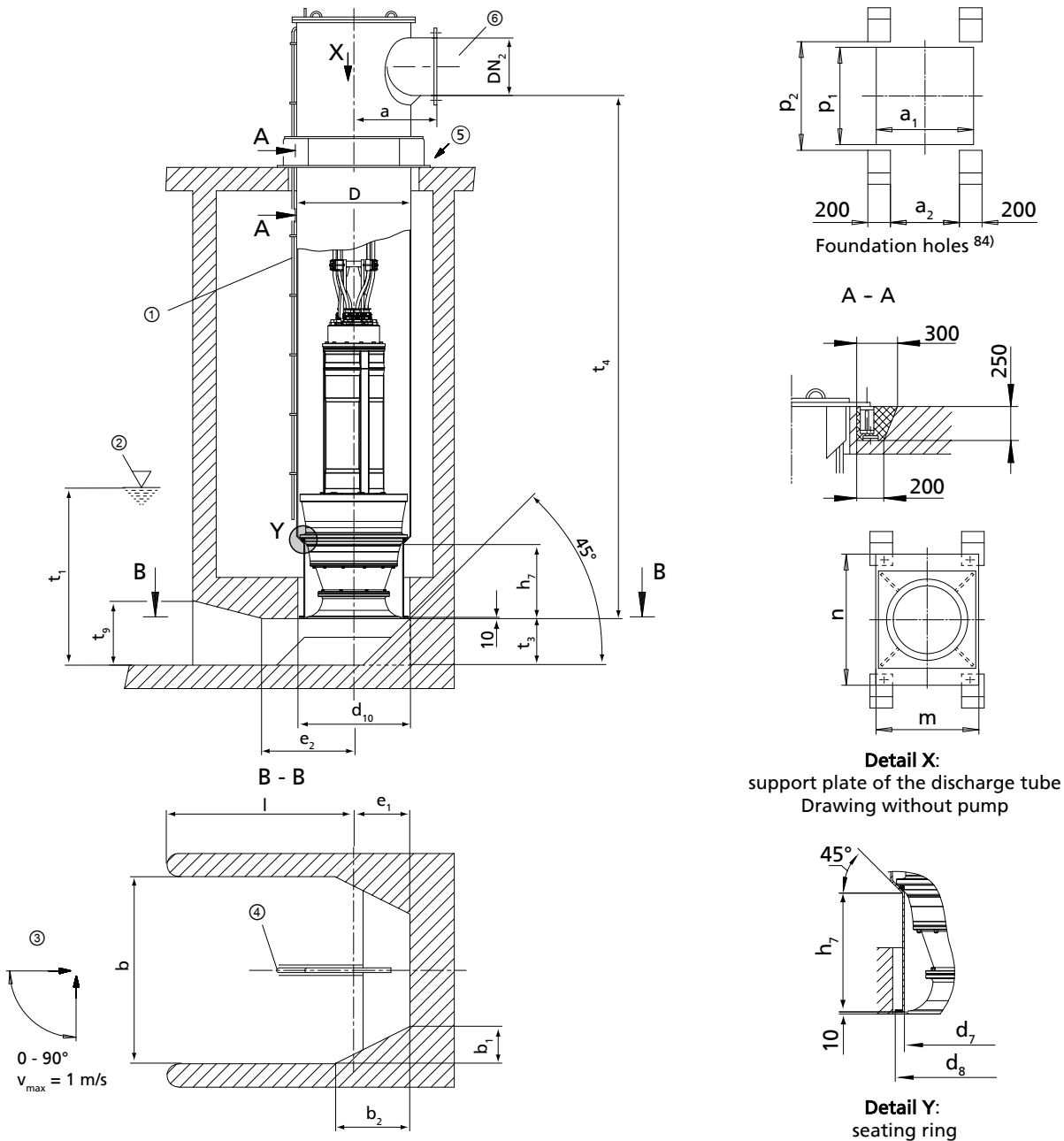

- ① Vent line
- ② Minimum water level (values see diagram on the next page)
- ③ Approach flow
- ④ Flow-straightening vane (⇒ Page 80)
- ⑤ Not pressure-proof
- ⑥ Connect the discharge pipe to the discharge tube without transmitting any stresses and strains.

All dimensions in [mm]

Pump size	D	DN ₂ min	DN ₂ max	a	a ₁	a ₂	b	b ₁	b ₂	d ₇	d ₈	d ₁₀
800 - 535	813	500	800	700	960	710	1500	300	600	720	840	885
850 - 550	868	500	800	730	1010	760	1500	300	600	740	840	885
900 - 600	914	600	900	760	1060	810	1500	300	600	800	820	860
900 - 615	914	600	900	760	1060	810	1800	360	720	780	910	955

⁸⁴⁾ All dimensions for foundation holes apply to discharge tube design without intermediate flange.

Pump size	D	DN ₂ min	DN ₂ max	a	a ₁	a ₂	b	b ₁	b ₂	d ₇	d ₈	d ₁₀
900 - 620	914	600	900	760	1060	810	1250	250	500	770	790	830
1000 - 655	1016	700	1000	810	1160	910	1800	360	720	920	1000	1040
1300 - 820	1320	1000	1300	960	1460	1210	2300	460	920	1080	1300	1360

All dimensions in [mm]

Pump size	e ₁ ⁸⁵⁾	e ₂	h ₇	l _{min}	m	n	p ₁	p ₂	t ₃ ⁸⁵⁾	t ₄ min ⁸⁶⁾	t ₉
800 - 535	450	750	325	1500	1030	1260	960	1060	380	2800	570
850 - 550	450	750	375	1500	1080	1310	1010	1110	380	3250	570
900 - 600	450	750	415	1500	1130	1360	1060	1160	380	3200	570
900 - 615	520	900	420	1800	1130	1360	1060	1160	440	3200	660
900 - 620	415	625	365	1250	1130	1360	1060	1160	320	3200	470
1000 - 655	520	900	515	1800	1240	1500	1160	1260	440	3750	660
1300 - 820	680	1150	545	2300	1540	1800	1460	1560	560	3900	850

Permissible tolerances:

- Tolerances in building construction to DIN 18202, Part 4, Group B
- Welded constructions: B/F to DIN EN ISO 13920
- Tolerances for conical seat (detail Y): ISO 2768-mH
- Discharge flanges to DIN EN 1092-1 PN6, DIN EN 1092-2 PN6

⁸⁵⁾ Always observe this dimension.

⁸⁶⁾ Value for maximum motor length

Loss diagram

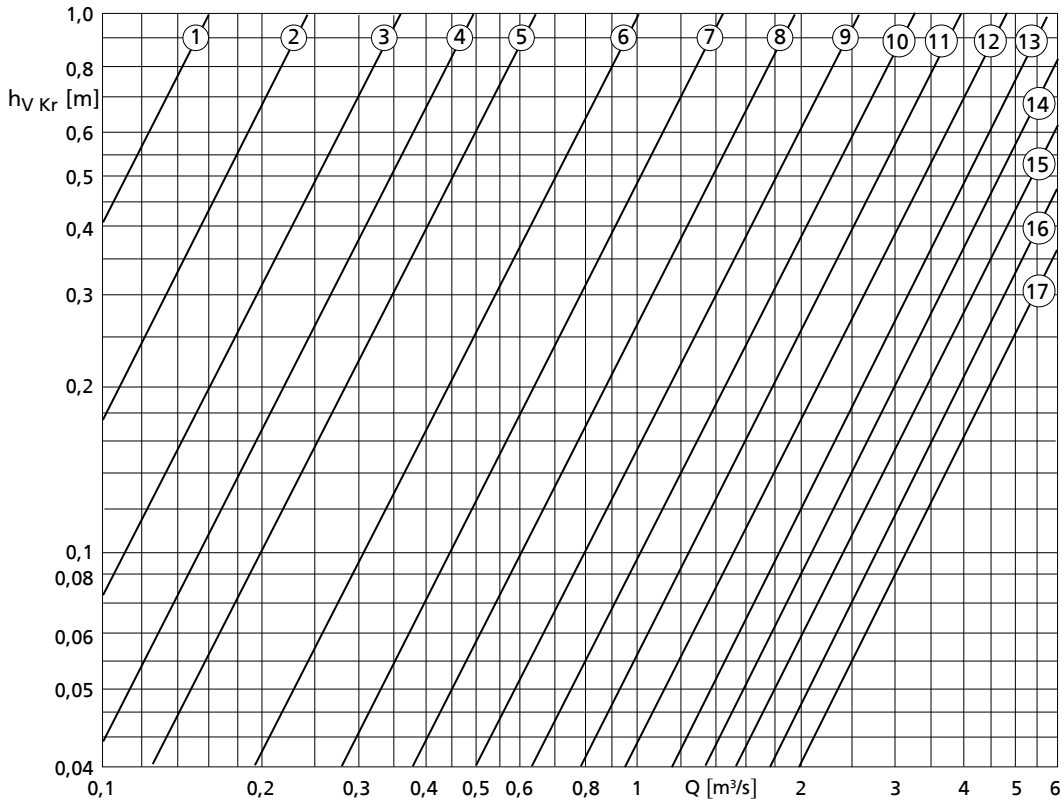

- | | | |
|------------------------------|-------------------------------|-------------------------------|
| ① - DN ₂ = 200 mm | ⑦ - DN ₂ = 600 mm | ⑬ - DN ₂ = 1200 mm |
| ② - DN ₂ = 250 mm | ⑧ - DN ₂ = 700 mm | ⑭ - DN ₂ = 1300 mm |
| ③ - DN ₂ = 300 mm | ⑨ - DN ₂ = 800 mm | ⑮ - DN ₂ = 1400 mm |
| ④ - DN ₂ = 350 mm | ⑩ - DN ₂ = 900 mm | ⑯ - DN ₂ = 1500 mm |
| ⑤ - DN ₂ = 400 mm | ⑪ - DN ₂ = 1000 mm | ⑰ - DN ₂ = 1600 mm |
| ⑥ - DN ₂ = 500 mm | ⑫ - DN ₂ = 1100 mm | |

Calculation formulas:

$$H = H_{\text{geo}} + \Delta H_V$$

$$\Delta H_V$$

- Loss in the elbow $h_{V, Kr}$ (see diagram)
- Loss in the riser (pipe friction)
- $H_{V, \text{System}}$ (valves, etc.)

$H_{V, \text{System}}$ must be determined for the specific system.

Diagram for minimum water level t_1

Covered chamber

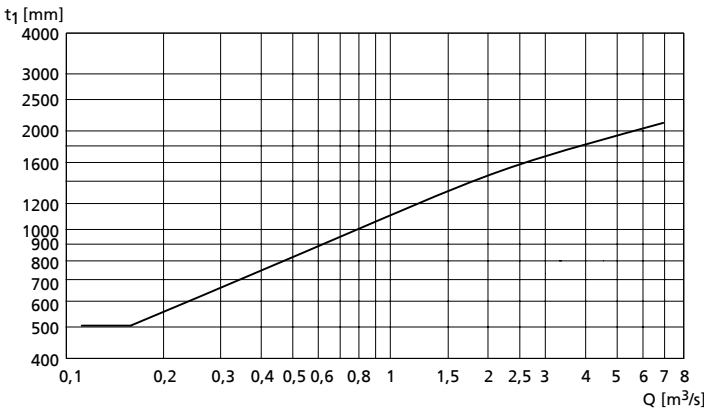

Minimum water level

Dimensions of the flow-straightening vane

Design of the inlet chamber wall surfaces (to prevent vortex formation)

The flow-straightening vane is indispensable for the inlet conditions of the pump. It prevents the development of a submerged vortex (floor vortex) which could cause a drop in performance, for example. In addition, the floor and wall surfaces of the intake chamber should be designed as a rough concrete surface. Rough surfaces minimize the separation of boundary layers that may cause wall and floor vortices.

Flow-straightening vane and inlet chamber

- The anti-swirl baffles in the bellmouth (part No. 138) must be aligned with the flow-straightening vane.
- The bail of the pump is oriented in the same direction as the baffles in the bellmouth.

1	Bail	2	Anti-swirl baffles
3	Flow-straightening vane		

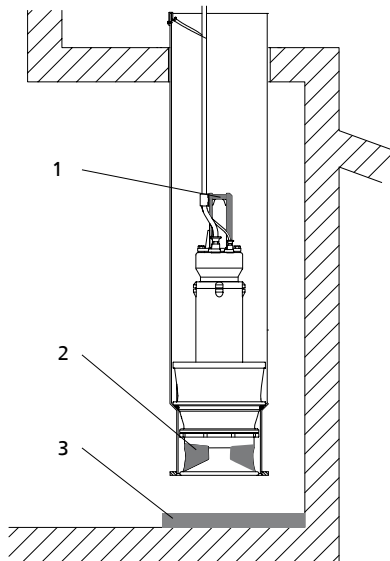

Installation position of the pump set

Variant 1 (concrete variant)
Flow-straightening vane cast from concrete

Variant 2
Steel section

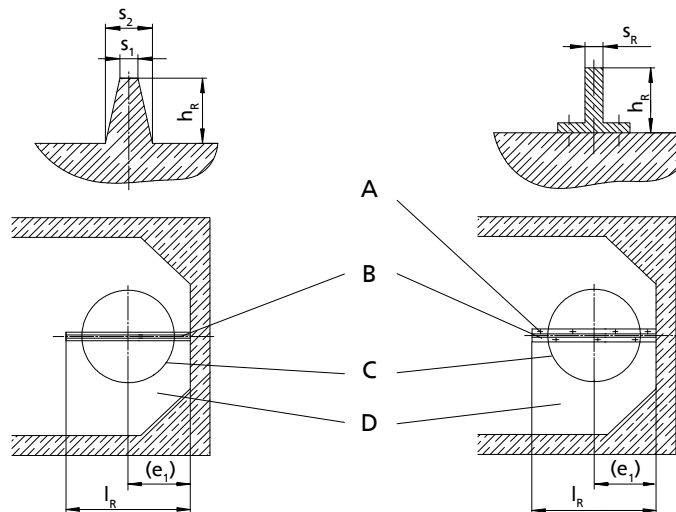

A	Bolted to the floor of the intake chamber	C	Discharge tube
B	Flow-straightening vane centered beneath the discharge tube	D	Intake chamber

Dimensions for installation types BU, CU, DU

Dimensions in [mm]

Size	h_R	s_R	s_1	s_2	$(e_1)^{87)}$		l_R	
					Design without suction umbrella d_8	Design with suction umbrella d_9	Design without suction umbrella d_8	Design with suction umbrella d_9
650-364	150	10	20	60	420	540	835	955
650-365	150	10	20	60	420	540	835	955
650-404	150	10	20	60	420	540	835	955
650-405	190	10	20	70	420	540	875	1050
800-505	190	10	20	70	500	620	1050	1150
800 - 535	230	10	25	90	500	750	1100	1350
850 - 550	230	10	25	90	525	750	1100	1350
900 - 600	230	10	25	90	550	750	1200	1500
900 - 615	265	12	25	100	550	750	1300	1500
900 - 620	190	10	20	70	550	620	1050	1150
1000 - 655	265	12	25	100	600	850	1300	1500
1300 - 820	335	12	30	120	750	1000	1625	1875

Dimensions for installation types BG, CG, DG

Dimensions in [mm]

Size	h_R	s_R	s_1	s_2
650-364	150	10	20	60
650-365	150	10	20	60
650-404	150	10	20	60
650-405	190	10	20	70
800-505	190	10	20	70
800 - 535	230	10	25	90
850 - 550	230	10	25	90
900 - 600	230	10	25	90
900 - 615	265	12	25	100
900 - 620	190	10	20	70
1000 - 655	265	12	25	100
1300 - 820	335	12	30	120

 Length l_R of the flow-straightening vane must be adjusted to the 45° angle of the inlet chamber.

87) See installation examples for types BU, CU and DU



KSB, Inc.

4415 Sarellen Road • Richmond, VA 23231

Phone: (804) 222-1818 • Fax: (804) 226-6961 • www.ksbusa.com

KSB PUMPS Inc.

5885 Kennedy Road • Mississauga • Ontario L 4Z 2G3

Phone: (905) 568-9200 • Fax: (905) 568-3740 • www.ksb.ca